



Trunnion Mounted & High Pressure Ball Valves

SWI
VALVE

SWI Valve Co., Ltd

Reliable Performance In Extreme Conditions

www.swivalve.com



● SWI Global Footprint

Wherever industrial valves are needed in the world, SWI is nearby. We maintain strong partnerships with authorized stocking distributors on every continent. For your nearest authorized stocking distributor or representative, full contact details can be obtained from our web site: www.swivalve.com



● Foreword

SWI Valve Co., Ltd. is a leading industrial valve manufacturing company, specializing in the design and manufacture of Ball, Gate, Globe, Check, Cryogenic and Bellows Seal valves.

Our facilities incorporate all aspects of valve design, development and manufacture ensuring that SWI can offer a degree of flexibility rarely encountered elsewhere.

At SWI, we stand for three values - quality, innovation and service. We know the worlds Oil, Chemical, Petrochemical and Process industries require precision flow control products. We have dedicated ourselves to supplying that need with an extensive range of industrial valves, manufactured in our own factories and designed for environmental sensitivity.

The Quality Policy of SWI Valve Co., Ltd. is to consistently provide product that meets customer and applicable regulatory requirements, with the aim to enhance customer satisfaction by providing exactly what has been agreed contractually, to the required quality and time stated.

The company operates under the Quality Assurance Scheme which is in accordance with ISO 9001 and API Monogram.

We are pleased to introduce our range of High Integrity Trunnion Mounted Ball Valves and trust this catalogue will assist our customers in the selection and application of SWI product.



DESIGN FEATURES



SWI trunnion mounted ball valves have been designed for Severe Service and generally used in the Petrochemical, Refining, Upstream Oil and Gas, Power and Chemical applications. The designs incorporate many technically advanced features which ensure reliable and repeatable shut off performance whilst providing the highest levels of safety as demanded by these industries.

TECHNICAL SPECIFICATIONS

Size Range	: DN50 (2") to DN1200 (48")
Pressure Rating	: ANSI Class 150 to Class 2500
Connection	: Flanged to ASME B16.5 (2" ~ 24") and ASME B16.47 Series A (26" and above) Butt-weld ends to ASME B16.25 Clamp / Hub ends on request.
Body Materials	: Carbon steel, ITCS, Stainless steel, Carbon steel + Inconel 625 cladding Duplex, Super Duplex, Inconel 625 and other special alloys.
Top Mounting	: ISO 5211 / EN15081 available.
Temp. Range	: -196°C to +538°C (-320°F to +1000°F)
Design	: API 6D / ASME B16.34 / ISO 14313
Face to Face	: ASME B16.10 / API 6D
Fire Testing	: API 607 6th Edition / ISO 10497
Pressure Testing	: API 598 / API 6D / EN 12266-1/ISO 5208
Certification	: EN 10204 / ISO 10474 / EN 29001/ NACE MR 0175 / ISO 15156 / MR 0103 Directives PED 97/23/EC & ATEX 94/9/EC ISO 15848 Part 1 & 2, API 622
Quality Assurance	: ISO 9001 / API Spec Q1/ API

TRUNNION MOUNTED BALL VALVES FOR THE CHEMICAL, PETROCHEMICAL, OIL & GAS AND ALLIED INDUSTRIES.
Pressure Classes 150 ~ 2500

KEY FEATURES

- Design, manufacture and materials conform to the essential requirements of API 6D, ISO 14313, ASME B16.34, ASME VIII and Directives PED 97/23/EC and ATEX 94/9/EC.
- Certified firesafe in accordance with API 607 6th Edition / ISO 10497.
- Anti-static design (10Ω under 12 Volt).
- Fully contained body gasket, graphite seal is protected from the working fluid by primary elastomeric seal for soft seated.
- Body wall thickness exceeds the minimum requirements of ASME B16.34.
- Full and reduced bore soft and metal seated designs available.
- Trunnion supported ball design for superior bi-directional shut off performance across a wide range of pressures.
- 2 or 3 piece bolted body construction for ease of on-site maintenance.
- Internally assembled blow-out proof stem design. Bottom entry stem shouldered directly to the body and not to any other intermediate part bolted to the valve.
- High integrity stem sealing system as standard, suitable for high vacuum service and technically emission free.
- In line maintainable stem sealing system. Replaceable without the need for valve disassembly or removal from the pipeline.
- Bi-directional, double block & bleed design allowing the venting and draining of the body in the open & closed position.
- Pressure and spring assisted seat design is of the single piston effect as standard.
- Positive cavity relief via spring loaded seat design to the low pressure side.
- Guided stem (bearings) with hardness control between parts to minimize operational torques.
- Positive seat sealing at high and low differential pressures.
- Emergency sealant injection provision to seat and stem seal is available.
- Metal seated designs for CRITICAL or SEVERE service applications.
- Low temperature and cryogenic service designs available.
- Testing and marking to API 6D & PED (when required).
- Available with pneumatic, hydraulic or electric actuators.

Quality Assurance

SWI operate under a Quality Assurance system which is approved by Bureau Veritas to ISO 9001:2008 / KS Q ISO 9001: 2009 / KEPIC -MN and the company is licensed to use the API Monogram in respect of API 6D ball valves. In line with the companies high reputation for quality of design and manufacture, SWI products have been independently accredited by Bureau Veritas for design, manufacture and materials compliant with the safety requirements of the Directive 97/23/EC (PED).

SWI's range of trunnion mounted and high pressure ball valve designs incorporate some of the most advanced features, including many major Owner & Operating Company specification preferences, whilst fully conforming to the design requirements of ISO 14313 / API 6D & ASME B16.34 codes.

Trunnion mounted designs provide reliable sealing at the upstream or high pressure side through spring and pressure assisted seats. The supported fixed ball has two independent spring assisted seat rings which are free to move along the valve axis providing bubble tight and bi-directional sealing capability. The seal is formed by the seat ring assembly being spring loaded & pressure energised against the ball as a result of the piston effect created by the fluid pressure. At low pressures, the sealing is maintained by the force provided by the seat springs.

All these design features contribute towards the valves capability to provide the highest levels of performance and reliability, whilst ensuring repeatable shut off, positive sealing of all external leak paths and a high degree of safety for both plant and personnel.

THE RANGE

FULL BORE

SIZE (Ins)	2"	3"	4"	6"	8"	10"	12"	14"	16"	18"	20"	24"	26"	28"	30"	36"	40"
ANSI 150	■	■	■	■	■	■	■	■	■	■	■	■	■	■	■	■	■
ANSI 300	■	■	■	■	■	■	■	■	■	■	■	■	■	■	■	■	■
ANSI 600	■	■	■	■	■	■	■	■	■	■	■	■	■	■	■	■	■
ANSI 900	■	■	■	■	■	■	■	■	■	■	■	■	■	■	■	■	■
ANSI 1500	■	■	■	■	■	■	■	■	■	■	■	■	■	■	■	■	■
ANSI 2500	■	■	■	■	■	■	■	■	■	■	■	■	■	■	■	■	■

REDUCED BORE

SIZE (Ins)	2"	3"	4"	6"	8"	10"	12"	14"	16"	18"	20"	24"	26"	28"	30"	36"	48"
ANSI 150	■	■	■	■	■	■	■	■	■	■	■	■	■	■	■	■	■
ANSI 300	■	■	■	■	■	■	■	■	■	■	■	■	■	■	■	■	■
ANSI 600	■	■	■	■	■	■	■	■	■	■	■	■	■	■	■	■	■
ANSI 900	■	■	■	■	■	■	■	■	■	■	■	■	■	■	■	■	■
ANSI 1500	■	■	■	■	■	■	■	■	■	■	■	■	■	■	■	■	■
ANSI 2500	■	■	■	■	■	■	■	■	■	■	■	■	■	■	■	■	■

· Larger sizes available on request.

■ SERIES CS - 2 PCE ■ SERIES CT - 3 PCE

BOLTED CONSTRUCTION

Designs are of the split body end entry bolted construction to facilitate ease of disassembly for maintenance purposes.

The double sealing action of the O-ring and fully contained graphite seals or Spiral Wound Gaskets design, ensures zero leakage and fire safety assurance.

All bolting calculations satisfy the requirements of ASME B16.34. In particular, allowable bolt stress used in the body or bonnet joints do not exceed the maximum value of either 7,000 or 9,000 psi respectively whichever bolt material is used.

The design complies with the requirements of ASME B16.34. Other codes (in particular ASME VIII Division 1) are only used as a supplement to ASME B16.34 for additional calculations not already covered in ASME B16.34.

DESIGN FEATURES

SWI's range of trunnion mounted ball valves are available in a wide range of materials and configurations to meet your specific requirements. Some options available include;

- Full internal cladding with corrosion resistant material.
- Sealant injection to seat and / or stem area.
- Metal seats & special coatings.
- Designs suitable for Pigging
- Combined Drain and Vent Connections with thread protection.
- Pneumatic, Electric or Hydraulic Automation.
- Emergency Shut Down applications.
- Extended bonnets for low temperature or cryogenic service.
- Underground (buried) service designs
- Locking & Interlocking Facilities.

ISO 15848-1 Class AH Certified

Weatherproof wiper seal to prevent environmental contamination to stem sealing element.

Anti-blow-out bottom entry stem shouldered to the body. Stem retention does not rely on any intermediate bolted part.

Combined Vent & Drain Valve for Block & Bleed Function and Seat Integrity Verification.

ISO 5211 mounting pad. Allows precise mounting of actuator, mounting bolts are independent from bonnet and exact alignment prevents side load and out-of-line wear.

Double sealing on stem. All seals can be field replaced without the need to remove the stem from the valve.

Large self lubricating steel bearings for smooth operation and lower operating torques.

Pressure & spring assisted seat design for positive sealing at high and low pressures with positive cavity relief.

6" CS Class 2500# Trunnion Mounted General Service Ball Valve

Standard insert materials include Reinforced PTFE, DEVLON V-API or PEEK

Firesafe body gasket protected by O-ring primary seal.

Bolted Construction, Field Serviceable

Secondary metal to metal Firesafe Seat

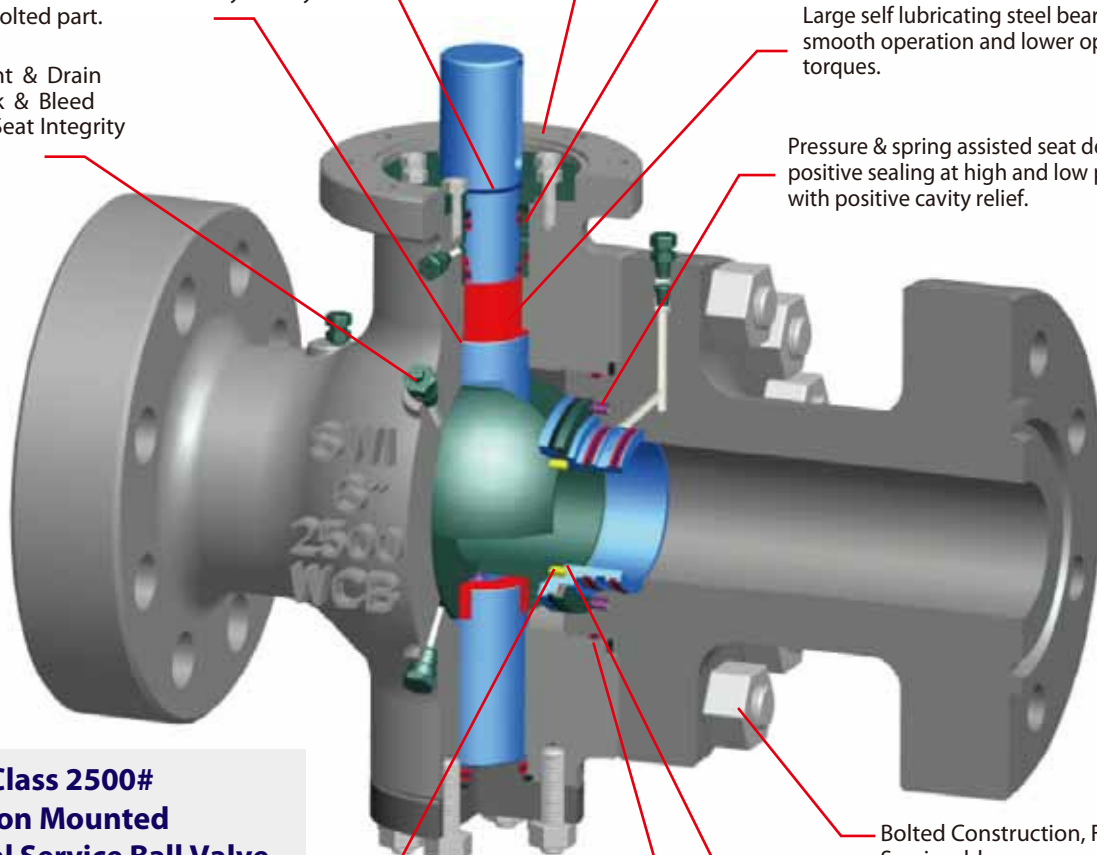

TRUNNION MOUNTED CONSTRUCTION

The trunnion mounted ball with its floating seat rings allows easy and smooth operation even at high pressures. The differential load, produced by line pressure acting on the ball, is carried by the stem and trunnion bearings. These self lubricating, PTFE coated bearings maintain low operating torque and maximises service life.

High temperature valves utilize solid metal bearings specially treated to ensure anti-galling and low friction characteristic.

Design is based on "Pin" or "Plate" trunnion support principle depending on valve size and pressure class.

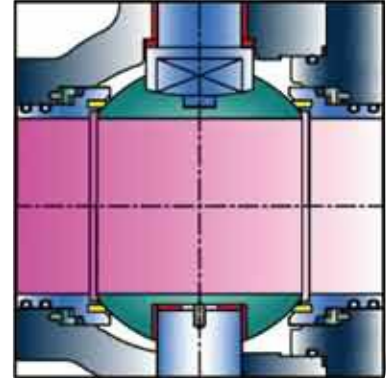

DOUBLE BLOCK & BLEED

SWI ball valve upstream and downstream positive sealing system allows for installation in services requiring double block and bleed facility for bleeding of the cavity or checking of the sealing integrity in the open or closed position.

When fitted, bleed valves or combined anti-blow-out vent & drain facility may be opened to check seat integrity with the main valve in either the fully open or closed position. Since there is no leak path from the pipeline to the body cavity other than via the seats or seat seals, bleeding the body cavity will indicate any leakage.

Seat / seal integrity may therefore be checked if needed PRIOR to affecting a pipeline shutdown.

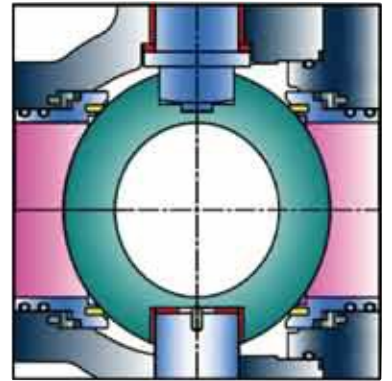

SELF RELIEVING FLOATING SEAT RINGS

Two independent single piston effect self relieving floating seat rings specially designed to minimize operational torque, ensure bi-directional tightness of the valve from zero differential pressure to the valves maximum rated pressure.

Double O-ring and Anti-extrusion rings are fitted as standard for class 2500 valves, and are optional for lower pressure classes.

To retain adequate sealing in the event of fire damage to the elastomeric primary seals, each is backed up by Energized Graphite by way of the seat spring. In the case of Soft Seated valves, destruction of the soft insert material will lead to the seat spring energising the metal seat ring to form a metal to metal seal against the ball.

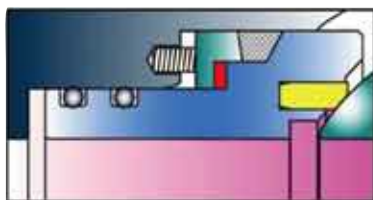

General Service

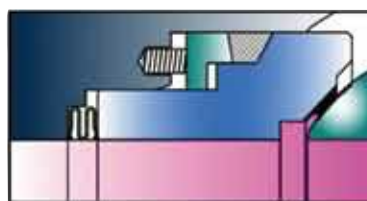

High Temperature Metal Seated

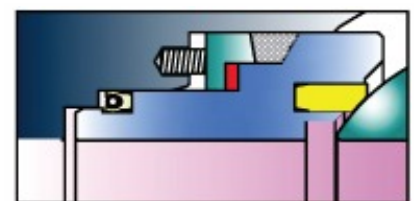

Low Temperature

Typical Seat Designs For 6" Valves & Above

POSITIVE CAVITY RELIEF

In the event of excessive pressure build-up in the body cavity (whilst the valve is fully open or closed) due to rapid thermal expansion of the trapped fluid, the excess will be relieved to the pipeline as the seat spring is overcome on the lowest differential pressure side.

DESIGN FEATURES

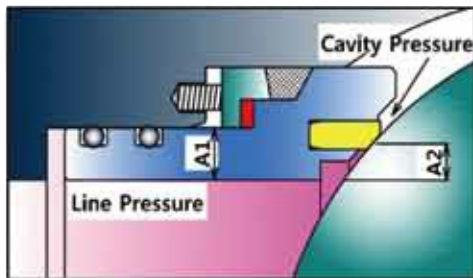

Seating Force = Line Pressure x (A1 - A2) + Spring Force.

PRESSURE ASSISTED SEALING

The high pressure side seal is formed by the seat ring assembly being pressure energised against ball as a result of the spring loaded seat combined with the single piston action created by the line pressure.

SPRING ASSISTED SEALING

Live loading of the seat rings by springs assures sealing capability at low pressures.

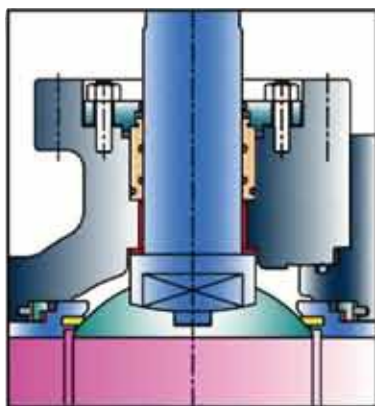

ANTI-BLOW-OUT STEM

The stem is of one piece bottom entry shouldered to body design as standard. No portion of the stem relies on any intermediate part of the body bonnet or cover or gland for its final positioning or anti-blow-out feature and the weakest point of the stem is outside of the pressure boundary.

This features combined with greater stem diameter & drive chain strength compared to many other manufacturers, ensures the stem drive train assembly is suitable for ESD applications as standard.

STEM SEALING

Precision machining of the stem which is rigidly supported between bearings, combined with hardness control between metallic parts and double O-rings backed up by a secondary graphite seal, ensures reliable operation with the highest levels of sealing integrity.

All seals can be replaced without the need to remove the stem from the valve or remove the valve from the pipeline.

Designs incorporating PTFE / Inconel Lip Seals, high integrity mechanically energised graphite or a combination of both, ensures sealing designs suitable for services from -200°C to + 538°C (-328°F to +1000°F), including low fugitive emission control for VOC, Hazardous and Lethal service applications.

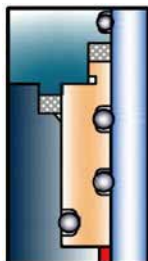

General Service

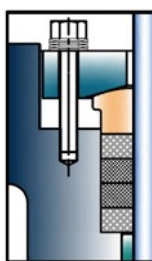

High Temp. Service

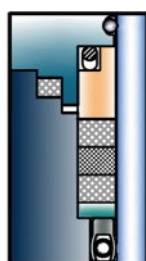

Low Temp. Service

EXPLOSIVE DECOMPRESSION

Wherever valves are used on high pressure gas applications, there is a possibility of gas being absorbed into the molecular structure of elastomeric O-rings. If the valve is then subject to sudden decompression, the gas will expand rapidly and may damage the O-ring.

To eliminate this possibility, special AED O-ring seals (Certified by Independent Test Laboratory) or Lip seals, suitable for such service conditions are available.

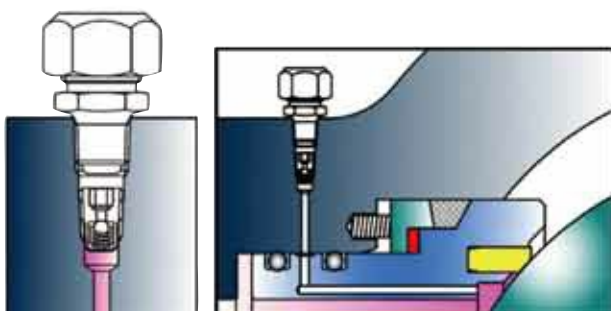

SEAT & STEM EMERGENCY SEALANT INJECTION

Valves can be supplied with emergency sealant injectors to the seat and stem seal area if required.

Special sealant is injected through fittings that are located between the double O-ring arrangement of the seat assembly or stem seal area to restore sealing integrity.

Emergency injection facility is not available on valves in low temperature service below -50°C (-58°F)

SEAT DESIGNS & MAIN MATERIALS

SIZE	General Service	High Temp. & Severe Service	Low Temperature
Valves ≤ DN100 (4")			
Valves ≥ DN150 (6")			

PERFORMANCE FOR ANY PROCESS

SWI recognizes the vital role correct seat material selection plays in delivering the highest levels of sealing performance and longevity of service which are directly effected by the process and operational requirements.

With a wide variety of SOFT & METAL seat materials to suit an extensive range of applications combined with advanced technology in design and construction, SWI offers dependable operation combined with pressure integrity and endurance over the valves service life. The below outlines commonly used seat materials; other grades are available on request.

R-PTFE < Reinforced Polytetrafluoroethylene >

This seating material has excellent chemical resistance over a wide range of chemicals and offers the lowest operational torques due to its lower coefficient of friction. Mechanical properties are enhanced by adding 25% percent glass fiber filler material to provide improved strength, stability and wear resistance.

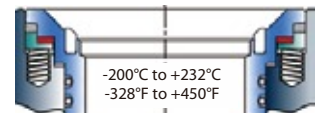

NYLON 6.12 / DEVLON V-API < High Molecular Polyamide Thermoplastic >

Devlon® V-API is a high molecular weight polyamide that is specifically tailored for high temperature/pressure applications in the offshore oil and gas sector. It is yellow in colour. The particularly low moisture absorption of this grade provides high dimensional stability combined with excellent impact wear characteristics to make this material invaluable for offshore applications.

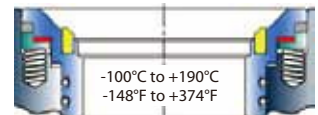

PEEK < Polyetheretherketone >

Pek Polymer offers a unique combination of chemical, mechanical and thermal properties where high strength and high temperature is required in corrosive applications. Excellent for water and steam application at elevated temperatures and possesses excellent resistance to radiation and abrasion compared to PTFE's.

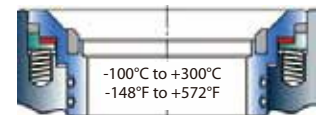

Metalized Carbon Insert

Metalized Carbon is a proprietary product for applications where traditional SOFT seating materials cannot be utilized. This material has exceptional capabilities and is suitable for use in a variety of SEVERE SERVICE applications ranging from high temperatures to cryogenic temperatures, harsh caustics and strong acids, dry service, whilst providing one of the lowest operational torques (coefficient of friction 0.1~0.2) due to its self-lubricating & non-galling characteristics. Being a solid and homogeneous material throughout; there are no coatings, plating or surface treatments to wear out.

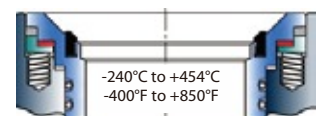

Solid Metal Seats

The complete failure of a valve in service is often due to the deterioration of its sealing element or one of the operating parts impairing its operation. Solid metal seats should be adopted for hostile conditions, CRITICAL and SEVERE applications, particularly when the service is dirty, abrasive, highly corrosive, at elevated temperature or a combination of all.

SWI offer a range of solid metal seating with various surface treatments such as NITRIDING or hard facing by thermal-spraying of STELLITE or TUNGSTEN CARBIDE or HARD NICKEL ALLOY to suit almost any application or base material. Stellite & Nickel Alloy coating can additionally be fully fused to the base metal to form a metallurgical bond providing the highest integrity sealing surface, virtually porous free with hardness up to 60 ~ 65 Hrc, dependant on alloy.

Precision lapping of ball & seat results in superior interfacing for tight shut-off.

Applications

- Slurries, pulp stock, scaling liquids
- Saturated & Superheated steam
- Fluids containing entrained particles, dirty service
- High pressure & high temperature applications
- Abrasive and erosive service applications

DESIGN FEATURES

VENT & DRAIN PLUG

Each valve is supplied with plugged Vent & Drain connections according to ASME B16.34 / API 6D located at the upper and lower part of the body. As standard, vent & drain connections are NPT thread. For smaller sizes of valves where sealant injection facility is required, a combined Vent & Drain Valve located in the lower part of the body is provided.

Where thread protection is specified or required, vent and drain connections can be provided with double O-ring seal to protect the thread in the body from service media and anti-blow-out designs are available.

Alternative design incorporating fully welded flange or a pad type flange connection, fitted with blind flange or gate valve are available.

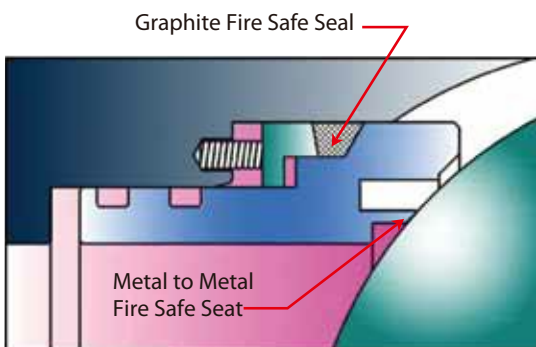
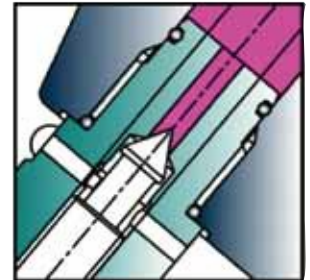

Seat Assembly After Fire

FIRE SAFETY

All SWI ball valves which incorporate polymeric or elastomeric seals are covered by Fire Test Certification in accordance with API 607 6th Edition / ISO 10497 and / or API 6FA. Metal seated valves with all graphite sealing elements are inherently firesafe.

Seals: - To retain adequate sealing in the event of fire damaging to the elastomeric primary seals, each is backed up by secondary energized graphite fire safe seal.

Seats: - Destruction of the soft seat insert material will lead to the seat spring energising the metal seat ring to form a metal to metal seal against the ball.

EXTENDED BONNET

Extended bonnet designs are of the bolted fully enclosed vapour space type with an internally assembled two part anti-blow-out stem design whereby all stem seals are located at the top of the bonnet away from the cold zone.

The one-piece bonnet design provides for a pressurised column in which the cold liquid phase is changed, by heat transfer with the environment, to the gaseous phase forming a gas gap under the primary stem seals which protects the valve from malfunctioning due to freezing.

SWI offer two extension lengths for each size of valve in accordance with internationally recognized practices such as Shell GSI MESC, BS6364 and MSS SP-134.

- Short Bonnet for temperatures between -30°C ~ -100°C
- Long Bonnet for temperatures below -101°C

The length of the extensions offered are sufficient to maintain the stem packing at a temperature high enough to permit operation within the normal temperature range of the packing material.

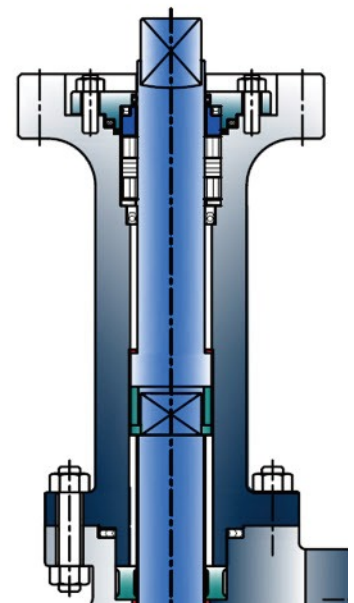

END CONNECTIONS

SWI ball valves can be supplied with ends flanged (RF or RTJ), prepared for welding (BW) or with special end connection preparation such as Hub Ends for clamped connections as per customer specifications.

Flanged RF or RTJ connections are according to ASME B16.5 up to 24" and ASME B16.47 Series A for 26" and larger. Other drillings available on request.

Butt weld end connections are according to ASME B16.25 as standard.

LOW TEMPERATURE & CRYOGENIC SERVICE

Trunnion mounted ball valves have been widely used in low temperature and cryogenic applications, including LNG (Liquefied Natural Gas) plants by major users and engineering contractors worldwide. SWI valve designs are available with extended bonnets and special preparation for applications in extreme temperature service conditions.

Extended bonnets are recommended for valves which are required to be operated (cycled open & closed) for service at temperatures below -30°C (-22°F) down to -196°C (-320°F).

SWI low temperature and cryogenic valves are designed with special consideration in the following areas.

- Vapour space extended bonnet to relocate the stem seals outside of the cold zone.
- Excellent seat & seal design to minimize potential for leakage.
- Bi-directional service capability with positive cavity relief.
- Lower operational torque for reliable and smoother operation.
- Rigid body construction to minimize effects of thermal shock.
- Fugitive emission compliance as standard.
- Modular design with ease of maintenance.
- Firesafe design.
- Drip collar, optional when specified.
- Acceptance test criteria.

EXTENDED BONNET

Extended bonnet designs are of the bolted fully enclosed vapour space type with an internally assembled two part anti-blow-out stem design whereby all stem seals are located at the top of the bonnet away from the cold zone.

The one-piece bonnet design provides for a pressurised column in which the cold liquid phase is changed, by heat transfer with the environment, to the gaseous phase forming a gas gap under the primary stem seals which protects the valve from malfunctioning due to freezing.

SWI offer two extension lengths for each size of valve in accordance with internationally recognized practices such as Shell GSI MESC, BS6364 and MSS SP-134.

- Short Bonnet for temperatures between -30°C ~ -100°C
- Long Bonnet for temperatures below -101°C

The length of the extensions offered are sufficient to maintain the stem packing at a temperature high enough to permit operation within the normal temperature range of the packing material.

DRIP COLLAR

The fitting of a drip collar helps to minimize ice accumulation on the extension and prevent possible damage to any lagging. Customers may specify the fitting of drip collars which is optional.

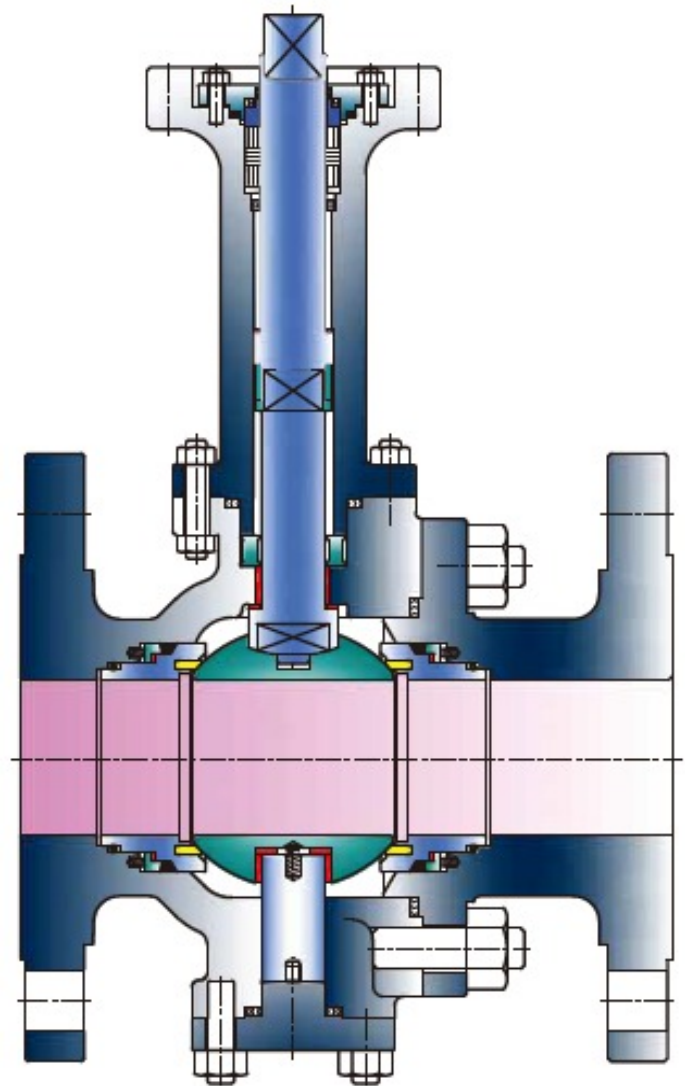

POSITIVE CAVITY RELIEF

In the event of excessive pressure build-up in the body cavity due to rapid thermal expansion of the trapped fluid, the excess will be relieved to the pipeline as the seat spring is overcome on the lowest differential pressure side.

DESIGN FEATURES

OPERATING TORQUE

Valves in low temperature and cryogenic service experience higher operational torques as a result of the increased rigidity of the seat material and changes in frictional coefficient. The level and variation in operational torques is dependant on the selected seat material and minimum operational service conditions. This increased operational torque must be taken into account when selecting operators or sizing for actuation. SWI have detailed experience of torque variations resulting from low temperature or cryogenic service and users are recommended to provide full application details to SWI technical for consideration.

MATERIAL TEMPERATURE LIMITS

The lower temperature limits for standard valve body materials are as follows;

BODY MATERIAL (ASTM)

Carbon Steel A216-WCB / A105N	-29°C	-20°F
Carbon Steel A352-LCB	-46°C	-50°F
Carbon Steel A352-LCC / A350-LF2	-50°C	-58°F
Stainless Steel A351-CF8M / A182-F316	-200°C	-328°F

SEAT MATERIAL

Reinforced PTFE	-200°C	-328°F
PEEK	-100°C	-148°F
PTFE (TFM1600)	-200°C	-328°F
PCTFE (Kel-F)	-250°C	-418°F

ACCEPTANCE TESTING

SWI's dedicated in-house test facilities enable valves to be performance tested at low temperature or cryogenic conditions in accordance with major international standards or a customer's individual requirements.

COOLANT	NITROGEN [N₂] - Liquid - Gaseous
TEST GAS	NITROGEN [99% N₂ + 1% He] - for temperatures down to -160°C (-256°F) HELIUM [He] - for temperatures down to -200°C (-328°F)
LEAKAGE DETECTION	EXTERNAL - by mass spectrometer ACROSS SEATS - by gas flow meters down to 5 nml/min, - then by soap bubble displacement for readings down to 0.1 Nm/min.

TEMPERATURE BAND DEFINITION

SWI have adopted the following band definitions for sub-zero services

BAND	TEMPERATURE RANGE
Low Temperature	-30°C ~ -100°C (-22°F ~ -148°F)
Cryogenic	-101°C (-150°F) & below

BOILING POINTS OF LIQUEFIED GASES

Propane	-42°C	-43.6°F
Carbon Dioxide	-78°C	-108.4°F
Ethylene	-104°C	-155.2°F
Methane	-161.5°C	-258.7°F
Liquid Natural Gas	-163°C	-261.4°F
Oxygen	-182.9°C	-297.2°F
Carbon Monoxide	-192°C	-313.6°F
Air	-194.4°C	-317.9°F
Nitrogen	-195.8°C	-320.4°F
Hydrogen	-252.7°C	-422.9°F
Helium	-268.9°C	-452°F



Series CS - Cast Valve
2-Piece, Class 150 ~ 2500

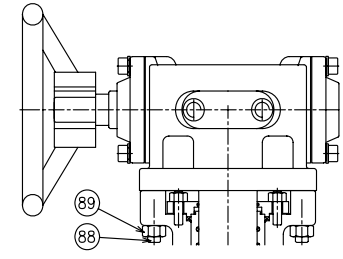
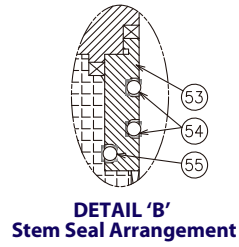
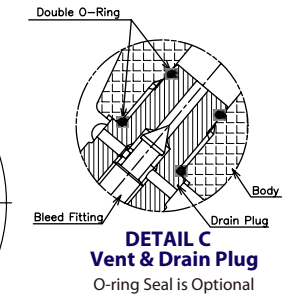
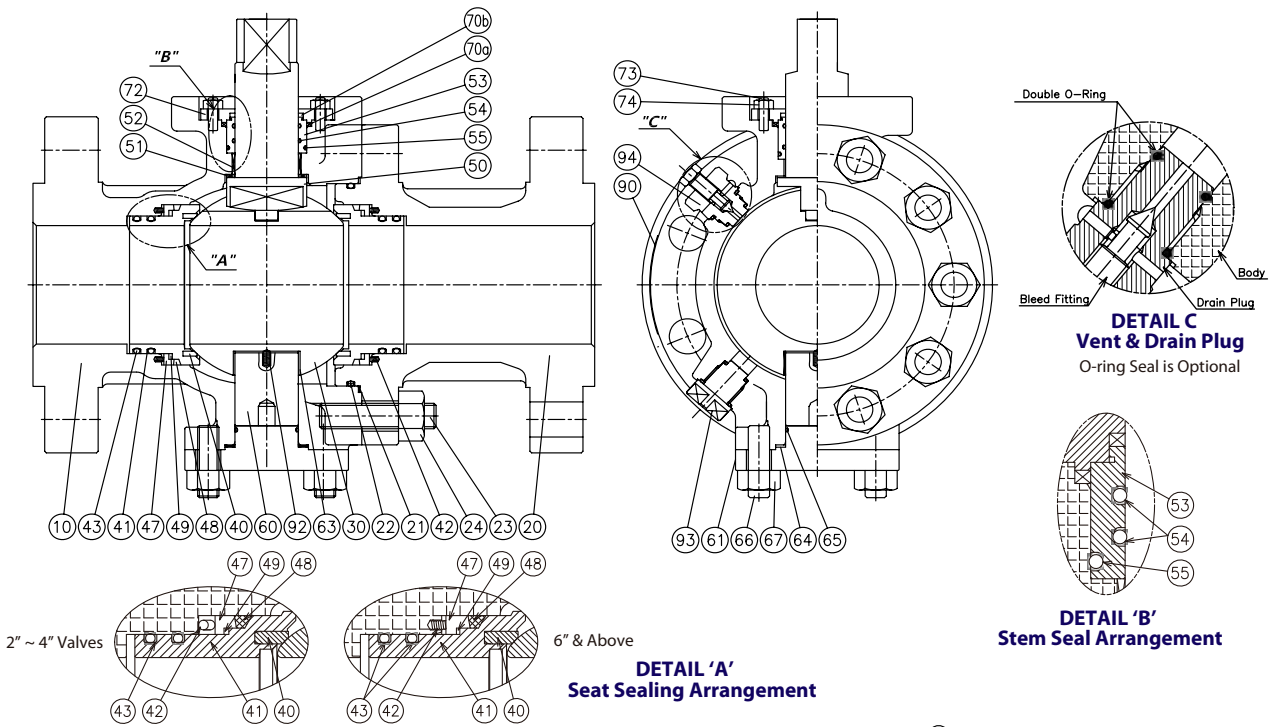

Gearbox Operator

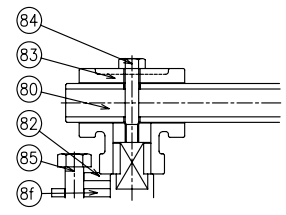

T-Bar Operator

BILL OF MATERIALS (1)							
No.	Part Description	Qty.	CS	ITCS	SS	Spares	Notes
10	BODY	1	A216-WCB	A352-LCC	A351-CF8M		
20	CAP (ADAPTOR)	1	A216-WCB	A352-LCC	A351-CF8M		
21	CAP GASKET	1	316+GRAPHITE SWG			S	
22	CAP O'RING	1	VITON B			S	3 & 4
23	CAP BOLT	1 Set	A193-B7	A320-L7	A193-B8M		2 & 5
24	CAP NUT	1 Set	A194-2H	A194-4	A194-8M		2 & 5
30	BALL	1	A182-F316 / A351-CF8M				
40	SEAT (SOFT INSERT)	2	RTFE or NYLON 6.12 or PEEK			S	6
41	SEAT RING / HOLDER	2	316 STAINLESS STEEL			S	
42	SEAT SPRING	1 Set	INCONEL X750				
43	SEAT O'RING	1 Set	VITON B			S	2, 3 & 4
47	SEAT RING ENERGIZER	2	316 STAINLESS STEEL				
48	SEAT RING FIRE SEAL	2	INHIBITED FLEXIBLE GRAPHITE			S	
49	ENERGIZER SPACER	2	RTFE			S	
50	STEM	1	316 STAINLESS STEEL				
51	THRUST DRY BEARING	1	316 STAINLESS STEEL + PTFE				
52	STEM DRY BEARING	1	316 STAINLESS STEEL + PTFE				
53	STEM BUSH	1	316 STAINLESS STEEL				
54	STEM O'RING	2	VITON B			S	3 & 4
55	BUSH O'RING	1	VITON B			S	3 & 4
60	TRUNNION	1	316 STAINLESS STEEL				
61	TRUNNION COVER	1	A105N	A350-LF2	A182-F316		
63	TRUNNION DRY BEARING	1	316 STAINLESS STEEL + PTFE				
64	LOWER COVER GASKET	1	316+GRAPHITE SWG			S	
65	LOWER COVER O'RING	1	VITON B			S	
66	COVER BOLT	1 Set	A193-B7	A320-L7	A193-B8M		2 & 5
67	COVER NUT	1 Set	A194-2H	A194-4	A194-8M		2 & 5
70a	STEM COVER SEAL	1	INHIBITED FLEXIBLE GRAPHITE			S	
70b	STEM COVER FIRE SEAL	1	INHIBITED FLEXIBLE GRAPHITE			S	
72	STEM COVER	1	A105N	A350-LF2	A182-F316		
73	STEM COVER BOLT	1 Set	A193-B7	A320-L7	A193-B8M		2 & 5
74	STEM COVER NUT	1 Set	A194-2H	A194-4	A194-8M		2 & 5
80	T-BAR TUBE	1	A395 + BLACK PAINT / A53 + GALVANIZED				
82	STOP PLATE	1	316 STAINLESS STEEL				
83	T-BAR SOCKET	1	A395				
84	T-BAR BOLT	1	A193-B8M				
85	STOP BOLT	1	A193-B8M				
87	WORM GEAR OPERATOR	1	COMMERCIAL				
88	GEAR MOUNTING BOLT	1 Set	A193-B7	A320-L7	A193-B8M		2 & 5
89	GEAR MOUNTING NUT	1 Set	A194-2H	A194-4	A194-8M		2 & 5
8d	T-BAR WASHER	1	316 STAINLESS STEEL				
8f	LOCKING PLATE	1	316 STAINLESS STEEL				
92	ANTI STATIC DEVICE	1	316 STAINLESS STEEL				
93	DRAIN / VENT PLUG	1 Set	316 STAINLESS STEEL				2

NOTES

1. Typical materials for standard valves.
2. Quantity is according to valve size & rating.
3. AED grade for Classes 600 ~ 2500 on request.
4. Double O-ring & anti-extrusion ring is optional for Classes below 2500#
5. For NACE grade 'M' applied
6. Maximum pressure Class for RTFE seat insert is Class 600#

S = Recommended Spares

Drawings are illustrations only. Parts may vary according to design and alternative material selections.

Always refer to Pressure - Temperature Tables to ensure correct Seat & Seal selection.

High Integrity Trunnion Mounted Ball Valves

Series CT - Cast Valve
3-Piece, Class 150 ~ 2500

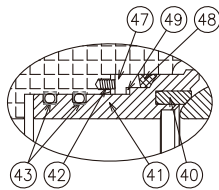
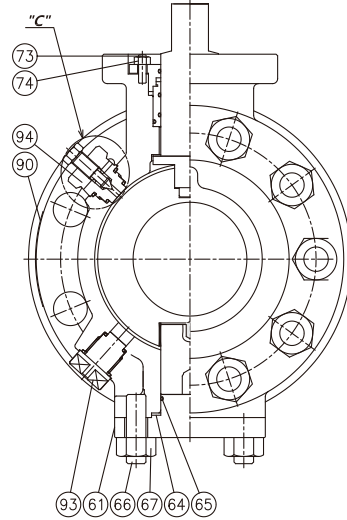
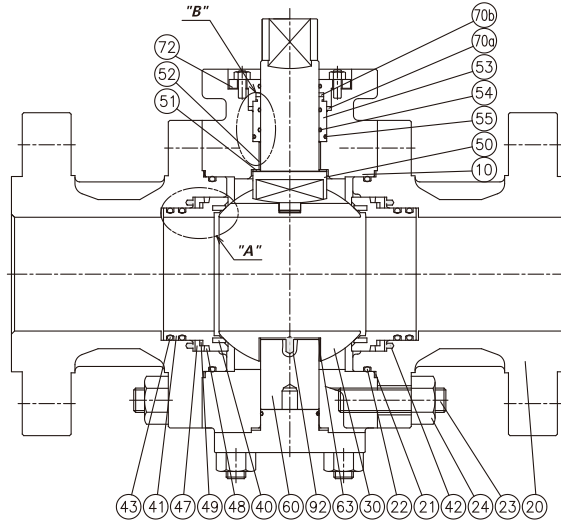

DETAIL 'A'
Seat Sealing Arrangement

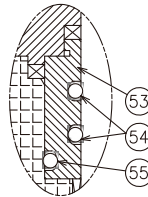

DETAIL 'B'
Stem Seal Arrangement

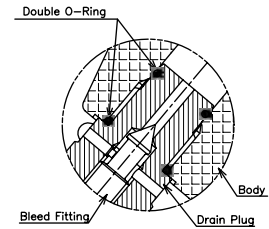

DETAIL C
Vent & Drain Plug

O-ring Seal is Optional

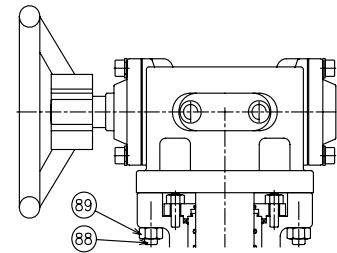

Gearbox Operator

BILL OF MATERIALS (1)							
No.	Part Description	Qty.	CS	ITCS	SS	Spares	Notes
10	BODY	1	A216-WCB	A352-LCC	A351-CF8M		
20	CAP (ADAPTOR)	2	A216-WCB	A352-LCC	A351-CF8M		
21	CAP GASKET	2	316+GRAPHITE SWG			S	
22	CAP O'RING	2	VITON B			S	3 & 4
23	CAP BOLT	1 Set	A193-B7	A320-L7	A193-B8M		2 & 5
24	CAP NUT	1 Set	A194-2H	A194-4	A194-8M		2 & 5
30	BALL	1	A182-F316 / A351-CF8M				
40	SEAT (SOFT INSERT)	2	RTFE or NYLON 6.12 or PEEK			S	6
41	SEAT RING / HOLDER	2	316 STAINLESS STEEL			S	
42	SEAT SPRING	1 Set	INCONEL X750				
43	SEAT O'RING	1 Set	VITON B			S	2, 3 & 4
47	SEAT RING ENERGIZER	2	316 STAINLESS STEEL				
48	SEAT RING FIRE SEAL	2	INHIBITED FLEXIBLE GRAPHITE			S	
49	ENERGIZER SPACER	2	RTFE			S	
50	STEM	1	316 STAINLESS STEEL				
51	THRUST DRY BEARING	1	316 STAINLESS STEEL + PTFE				
52	STEM DRY BEARING	1	316 STAINLESS STEEL + PTFE				
53	STEM BUSH	1	316 STAINLESS STEEL				
54	STEM O'RING	2	VITON B			S	3 & 4
55	BUSH OUTER O'RING	1	VITON B			S	3 & 4
60	TRUNNION	1	316 STAINLESS STEEL				
61	TRUNNION COVER	1	A105N	A350-LF2	A182-F316		
63	TRUNNION DRY BEARING	1	316 STAINLESS STEEL + PTFE				
64	LOWER COVER GASKET	1	316+GRAPHITE SWG			S	
65	LOWER COVER O'RING	1	VITON B			S	
66	COVER BOLT	1 Set	A193-B7	A320-L7	A193-B8M		2 & 5
67	COVER NUT	1 Set	A194-2H	A194-4	A194-8M		2 & 5
70a	STEM COVER SEAL	1	INHIBITED FLEXIBLE GRAPHITE			S	
70b	STEM COVER FIRE SEAL	1	INHIBITED FLEXIBLE GRAPHITE			S	
72	STEM COVER	1	A105N	A350-LF2	A182-F316		
73	STEM COVER BOLT	1 Set	A193-B7	A320-L7	A193-B8M		2 & 5
74	STEM COVER NUT	1 Set	A194-2H	A194-4	A194-8M		2 & 5
87	WORM GEAR OPERATOR	1	COMMERCIAL				
88	GEAR MOUNTING BOLT	1 Set	A193-B7	A320-L7	A193-B8M		2 & 5
89	GEAR MOUNTING NUT	1 Set	A194-2H	A194-4	A194-8M		2 & 5
92	ANTI STATIC DEVICE	1	316 STAINLESS STEEL				
93	DRAIN / VENT PLUG	1 Set	316 STAINLESS STEEL				2

NOTES

1. Typical materials for standard valves.
 2. Quantity is according to valve size & rating.
 3. AED grade for Classes 600 ~ 2500 on request.
 4. Double O-ring & anti-extrusion ring is optional for Classes below 2500#
 5. For NACE grade 'M' applied
 6. Maximum pressure Class for RTFE seat insert is Class 600#
- S = Recommended Spares

Drawings are illustrations only. Parts may vary according to design and alternative material selections.

Always refer to Pressure - Temperature Tables to ensure correct Seat & Seal selection.

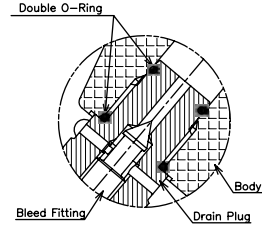
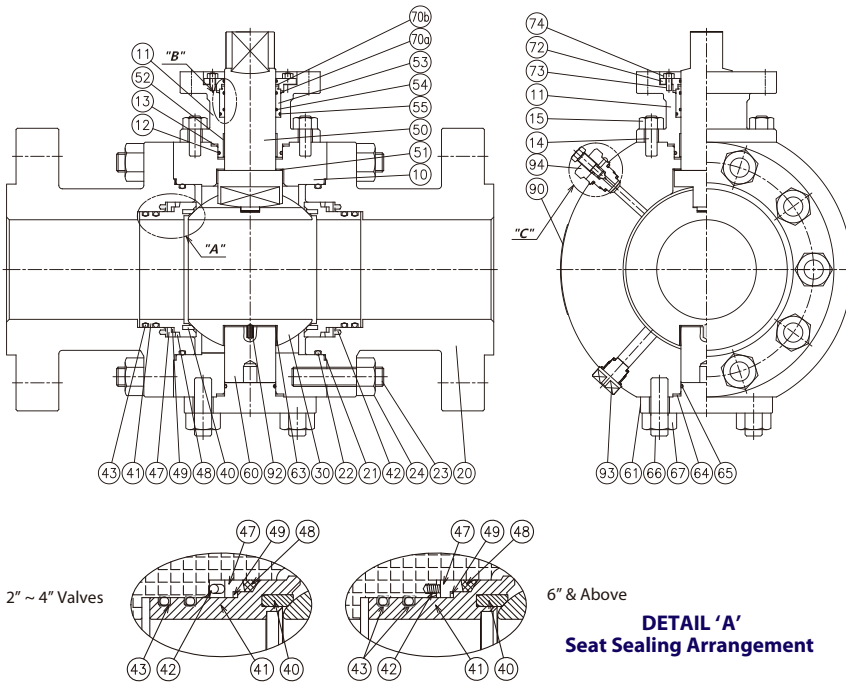

**DETAIL C
Vent & Drain
Plug**

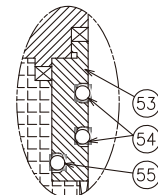

**DETAIL 'B'
Stem Seal Arrangement**

BILL OF MATERIALS (1)							
No.	Part Description	Qty.	CS	ITCS	SS	Spares	Notes
10	BODY	1	A105	A350-LF2	A182-F316		
11	BONNET	1	A105	A350-LF2	A182-F316		
12	BONNET O-RING	1	VITON B				3 & 4
13	BONNET GASKET	1	316+GRAPHITE SWG				
14	BONNET BOLT	1 Set	A193-B7	A350-LF2	A193-B8M		2 & 5
15	BONNET NUT	1 Set	A194-2H	A194-4	A194-8M		2 & 5
20	CAP (ADAPTOR)	2	A105	A350-LF2	A182-F316		
21	CAP GASKET	2	316+GRAPHITE SWG			S	
22	CAP O-RING	2	VITON B			S	3 & 4
23	CAP BOLT	1 Set	A193-B7	A320-L7	A193-B8M		2 & 5
24	CAP NUT	1 Set	A194-2H	A194-4	A194-8M		2 & 5
30	BALL	1	A182-F316 / A351-CF8M				
40	SEAT (SOFT INSERT)	2	RTFE or NYLON 6,12 or PEEK			S	6
41	SEAT RING/ HOLDER	2	316 STAINLESS STEEL			S	
42	SEAT SPRING	1 Set	INCONEL X750				
43	SEAT O-RING	1 Set	VITON B			S	2, 3 & 4
47	SEAT RING ENERGIZER	2	316 STAINLESS STEEL				
48	SEAT RING FIRE SEAL	2	INHIBITED FLEXIBLE GRAPHITE			S	
49	ENERGIZER SPACER	2	RTFE			S	
50	STEM	1	316 STAINLESS STEEL				
51	THRUST DRY BEARING	1	316 STAINLESS STEEL + PTFE				
52	STEM DRY BEARING	1	316 STAINLESS STEEL + PTFE				
53	STEM BUSH	1	316 STAINLESS STEEL				
54	STEM O-RING	2	VITON B			S	3 & 4
55	BUSH OUTER O-RING	1	VITON B			S	3 & 4
60	TRUNNION	1	316 STAINLESS STEEL				
61	TRUNNION COVER	1	A105N	A350-LF2	A182-F316		
63	TRUNNION DRY BEARING	1	316 STAINLESS STEEL + PTFE				
64	LOWER COVER GASKET	1	316+GRAPHITE SWG			S	
65	LOWER COVER O-RING	1	VITON B			S	
66	LOWER COVER BOLT	1 Set	A193-B7	A320-L7	A193-B8M		2 & 5
67	LOWER COVER NUT	1 Set	A194-2H	A194-4	A194-8M		2 & 5
70a	STEM COVER SEAL	1	INHIBITED FLEXIBLE GRAPHITE			S	
70b	STEM COVER FIRE SEAL	1	INHIBITED FLEXIBLE GRAPHITE			S	
72	STEM COVER	1	A105N	A350-LF2	A182-F316		
73	STEM COVER BOLT	1 Set	A193-B7	A320-L7	A193-B8M		2 & 5
74	STEM COVER NUT	1 Set	A194-2H	A194-4	A194-8M		2 & 5
80	T-BAR TUBE	1	A395 + BLACK PAINT / A53 + GALVANIZED				
82	STOP PLATE	1	316 STAINLESS STEEL				
83	T-BAR SOCKET	1	A395				
84	T-BAR BOLT	1	A193-B8M				
85	STOP BOLT	1	A193-B8M				
87	WORM GEAR OPERATOR	1	COMMERCIAL				
88	GEAR MOUNTING BOLT	1 Set	A193-B7	A320-L7	A193-B8M		2 & 5
89	GEAR MOUNTING NUT	1 Set	A194-2H	A194-4	A194-8M		2 & 5
8d	T-BAR WASHER	1	316 STAINLESS STEEL				
8f	LOCKING PLATE	1	316 STAINLESS STEEL				
92	ANTI STATIC DEVICE	1	316 STAINLESS STEEL				
93	DRAIN / VENT PLUG	1 Set	316 STAINLESS STEEL				2

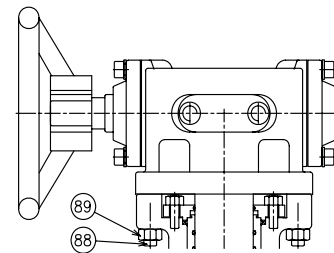

Gearbox

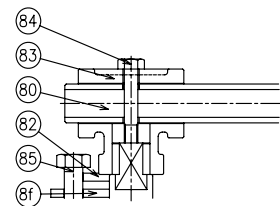

T-Bar

NOTES

1. Typical materials for standard valves.
 2. Quantity is according to valve size & rating.
 3. AED grade for Classes 600 ~ 2500 on request.
 4. Double O-ring & anti-extrusion ring is optional for Classes below 2500#
 5. For NACE grade 'M' applied
 6. Maximum pressure Class for RTFE seat insert is Class 600#
- S = Recommended Spares

Drawings are illustrations only. Parts may vary according to design and alternative material selections.

Always refer to Pressure - Temperature Tables to ensure correct Seat & Seal selection.

TECHNICAL DATA

STANDARD VALVE DIMENSIONS - Class 150

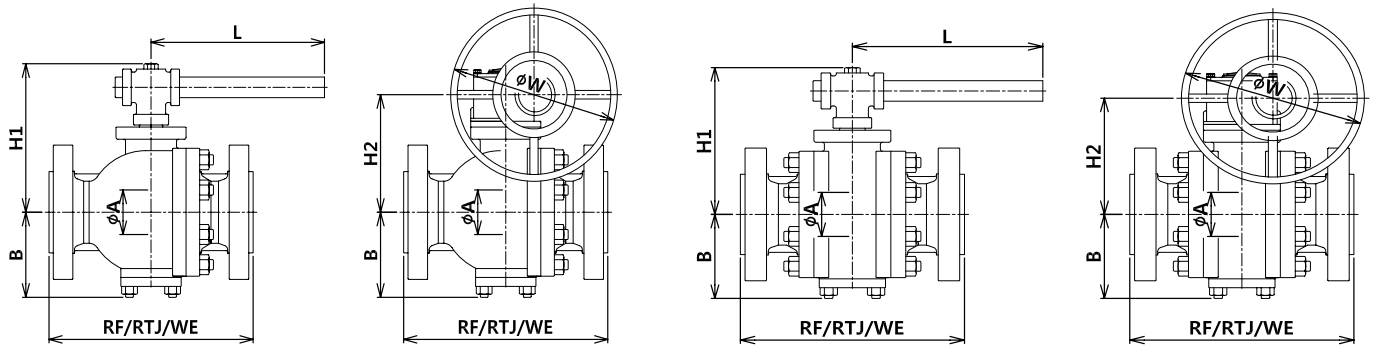

Class 150

* Available Series:

■ CS - 2pc

■ CT - 3pc

SIZE	*	BORE	ID BORE	RF	RTJ	BW	B	H1	L	H2	OD HW	WEIGHT (LBS)
2	FB	49(1.9")	178(7.0")	191(7.5")	216(8.5")	102(4.0")	132(5.2")	230(9.1")				40
	RB	38(1.5")	178(7.0")	191(7.5")	216(8.5")	86(3.4")	109(4.3")	200(7.9")				35
3	FB	74(2.9")	203(8.0")	216(8.5")	283(11.1")	125(4.9")	172(6.8")	400(15.7")				73
	RB	49(1.9")	203(8.0")	216(8.5")	283(11.1")	102(4.0")	132(5.2")	230(9.1")				58
4	FB	100(3.9")	229(9.0")	241(9.5")	305(12.0")	143(5.6")	194(7.6")	450(17.7")				124
	RB	74(2.9")	229(9.0")	241(9.5")	305(12.0")	125(4.9")	172(6.8")	400(15.7")				110
6	FB	150(5.9")	394(15.5")	406(16.0")	457(18.0")	185(7.3")	260(10.2")	800(31.5")		268(10.6")	300(11.8")	342
	RB	100(3.9")	394(15.5")	406(16.0")	457(18.0")	128(5.0")	220(8.7")	500(19.7")		228(9.0")	300(11.8")	300
8	FB	201(7.9")	457(18.0")	470(18.5")	521(20.5")	230(9.1")				285(11.2")	457(18.0")	638
	RB	150(5.9")	457(18.0")	470(18.5")	521(20.5")	185(7.3")				236(9.3")	457(18.0")	385
10	FB	252(9.9")	533(21.0")	546(21.5")	559(22.0")	254(10.0")				338(13.3")	457(18.0")	836
	RB	201(7.9")	533(21.0")	546(21.5")	559(22.0")	230(9.1")				285(11.2")	457(18.0")	726
12	FB	303(11.9")	610(24.0")	622(24.5")	635(25.0")	310(12.2")				392(15.4")	610(24.0")	1,276
	RB	252(9.9")	610(24.0")	622(24.5")	635(25.0")	254(10.0")				338(13.3")	457(18.0")	968
14	FB	334(13.2")	686(27.0")	699(27.5")	762(30.0")	337(13.3")				426(16.8")	762(30.0")	1,716
	RB	252(9.9")	686(27.0")	699(27.5")	762(30.0")	254(10.0")				338(13.3")	457(18.0")	1,419
16	FB	385(15.2")	762(30.0")	775(30.5")	838(33.0")	362(14.3")				464(18.3")	762(30.0")	2,266
	RB	303(11.9")	762(30.0")	775(30.5")	838(33.0")	310(12.2")				392(15.4")	610(24.0")	1,936
18	FB	436(17.2")	864(34.0")	876(34.5")	914(36.0")	411(16.2")				517(20.4")	762(30.0")	3,190
	RB	334(13.2")	864(34.0")	876(34.5")	914(36.0")	337(13.3")				426(16.8")	762(30.0")	2,508
20	FB	487(19.2")	914(36.0")	927(36.5")	991(39.0")	438(17.2")				575(22.6")	762(30.0")	3,960
	RB	385(15.2")	914(36.0")	927(36.5")	991(39.0")	362(14.3")				464(18.3")	762(30.0")	3,432
24	FB	589(23.2")	1067(42.0")	1080(42.5")	1143(45.0")	530(20.9")				693(27.3")	762(30.0")	6,204
	RB	487(19.2")	1067(42.0")	1080(42.5")	1143(45.0")	438(17.2")				575(22.6")	762(30.0")	5,500
26	FB	633(24.9")	1143(45.0")		1245(49.0")	570(22.4")				724(28.5")	762(30.0")	7,370
	RB	487(19.2")	1143(45.0")		1245(49.0")	438(17.2")				575(22.6")	762(30.0")	6,490
28	FB	684(26.9")	1245(49.0")		1346(53.0")	615(24.2")				794(31.3")	762(30.0")	9,306
	RB	589(23.2")	1245(49.0")		1346(53.0")	530(20.9")				693(27.3")	762(30.0")	7,788
30	FB	735(28.9")	1295(51.0")		1397(55.0")	698(27.5")				810(31.9")	762(30.0")	11,598
	RB	589(23.2")	1295(51.0")		1397(55.0")	530(20.9")				693(27.3")	762(30.0")	9,900
36	FB	874(34.4")	1524(60.0")		1727(68.0")	797(31.4")				930(36.6")	762(30.0")	18,172
	RB	735(28.9")	1524(60.0")		1727(68.0")	698(27.5")				810(31.9")	762(30.0")	16,940
40	FB	976(38.4")	1850(72.8")		1780(70.1")	898(35.4")				999(39.3")	762(30.0")	
	RB	874(34.4")	1850(72.8")		1727(68.0")	797(31.4")				930(36.6")	762(30.0")	
48	FB											
	RB	976(38.4")	2180(85.8")		2100(82.7")	898(35.4")				999(39.3")	762(30.0")	

WEIGHTS 8" AND LARGER WITH GEAR

STANDARD VALVE DIMENSIONS - Class 300

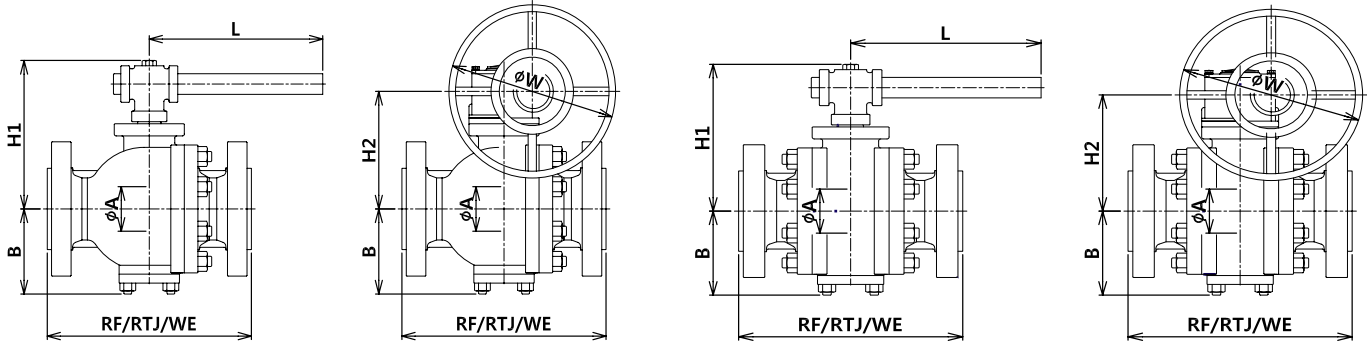

Class 300		SIZE	*	BORE	ID BORE	RF	RTJ	BW	B	H1	L	H2	OD HW	WEIGHT (LBS)
2	FB	49(1.9")	216(8.5")	232(9.12")	216(8.5")	102(4.0")	132(5.2")	230(9.1")						58
	RB	38(1.5")	216(8.5")	232(9.12")	216(8.5")	86(3.4")	109(4.3")	200(7.9")						53
3	FB	74(2.9")	283(11.12")	298(11.74")	283(11.125")	125(4.9")	172(6.8")	400(15.7")						100
	RB	49(1.9")	283(11.1")	298(11.74")	283(11.1")	102(4.0")	132(5.2")	230(9.1")						78
4	FB	100(3.9")	305(12.0")	321(12.62")	305(12.0")	143(5.6")	194(7.6")	450(17.7")						135
	RB	74(2.9")	305(12.0")	321(12.62")	305(12.0")	125(4.9")	172(6.8")	400(15.7")						125
6	FB	150(5.9")	403(15.88")	419(16.5")	457(18.0")	185(7.3")	260(10.2")	800(31.5")	268(10.6")	300(11.8")				386
	RB	100(3.9")	403(15.88")	419(16.5")	457(18.0")	128(5.0")	220(8.7")	500(19.7")	228(9.0")	300(11.8")				330
8	FB	201(7.9")	502(19.75")	518(20.37")	521(20.5")	230(9.1")				311(12.2")			457(18.0")	682
	RB	150(5.9")	502(19.75")	518(20.37")	521(20.5")	185(7.3")				268(10.6")			457(18.0")	464
10	FB	252(9.9")	568(22.38")	584(23.0")	559(22.0")	254(10.0")				358(14.1")			457(18.0")	902
	RB	201(7.9")	568(22.38")	584(23.0")	559(22.0")	230(9.1")				311(12.2")			457(18.0")	814
12	FB	303(11.9")	648(25.5")	664(26.12")	635(25.0")	310(12.2")				402(15.8")			610(24.0")	1,452
	RB	252(9.9")	648(25.5")	664(26.12")	635(25.0")	254(10.0")				358(14.1")			457(18.0")	1,056
14	FB	334(13.2")	762(30.0")	778(30.62")	762(30.0")	337(13.3")				528(20.8")			762(30.0")	2,035
	RB	252(9.9")	762(30.0")	778(30.62")	762(30.0")	254(10.0")				358(14.1")			457(18.0")	1,738
16	FB	385(15.2")	838(33.0")	854(33.62")	838(33.0")	362(14.3")				568(22.4")			762(30.0")	2,662
	RB	303(11.9")	838(33.0")	854(33.62")	838(33.0")	310(12.2")				402(15.8")			610(24.0")	2,233
18	FB	436(17.2")	914(36.0")	930(36.62")	914(36.0")	411(16.2")				665(26.2")			762(30.0")	3,740
	RB	334(13.2")	914(36.0")	930(36.62")	914(36.0")	337(13.3")				528(20.8")			762(30.0")	2,959
20	FB	487(19.2")	991(39.0")	1010(39.75")	991(39.0")	438(17.2")				680(26.8")			762(30.0")	4,664
	RB	385(15.2")	991(39.0")	1010(39.75")	991(39.0")	362(14.3")				568(22.4")			762(30.0")	4,180
24	FB	589(23.2")	1143(45.0")	1165(45.88")	1143(45.0")	530(20.9")				768(30.2")			762(30.0")	7,128
	RB	487(19.2")	1143(45.0")	1165(45.88")	1143(45.0")	438(17.2")				680(26.8")			762(30.0")	6,292
26	FB	633(24.9")	1245(49.0")		1245(49.0")	570(22.4")				807(31.8")			762(30.0")	9,900
	RB	487(19.2")	1245(49.0")		1245(49.0")	438(17.2")				560(22.0")			762(30.0")	7,920
28	FB	684(26.9")	1346(53.0")		1346(53.0")	615(24.2")				849(33.4")			762(30.0")	11,275
	RB	589(23.2")	1346(53.0")		1346(53.0")	530(20.9")				768(30.2")			762(30.0")	10,560
30	FB	735(28.9")	1397(55.0")		1397(55.0")	698(27.5")				990(39.0")			762(30.0")	12,760
	RB	589(23.2")	1397(55.0")		1397(55.0")	530(20.9")				693(27.3")			762(30.0")	11,660
36	FB	874(34.4")	1727(68.0")		1727(68.0")	797(31.4")				1080(42.5")			762(30.0")	20,240
	RB	735(28.9")	1727(68.0")		1727(68.0")	698(27.5")				990(39.0")			762(30.0")	18,920
40	FB	976(38.4")	1850(72.8")		1780(70.1")	898(35.4")				1149(45.2")			762(30.0")	
	RB	874(34.4")	1850(72.8")		1727(68.0")	797(31.4")				1080(42.5")			762(30.0")	
48	FB				1727(68.0")									
	RB	976(38.4")	2180(85.8")		2100(82.7")	898(35.4")				1149(45.2")			762(30.0")	

WEIGHTS 8" AND LARGER WITH GEAR

TECHNICAL DATA

STANDARD VALVE DIMENSIONS - Class 600 & 900

Class 600		SIZE	*	BORE	ID BORE	RF	RTJ	BW	B	H1	L	H2	OD HW	WEIGHT (LBS)
2	FB	49(1.9")		292(11.5")	295(11.62")	292(11.5")	102(4.0")	146(5.7")	400(15.7")					66
	RB	38(1.5")		292(11.5")	295(11.62")	292(11.5")	94(3.7")	132(5.2")	260(10.2")					53
3	FB	74(2.9")		356(14.0")	359(14.12")	356(14.0")	140(5.5")	210(8.3")	460(18.1")					132
	RB	49(1.9")		356(14.0")	359(14.12")	356(14.0")	102(4.0")	146(5.7")	460(18.1")					68
4	FB	100(3.9")		432(17.0")	435(17.12")	432(17.0")	172(6.8")	238(9.4")	600(23.6")	246(9.7")	300(11.8")			198
	RB	74(2.9")		432(17.0")	435(17.12")	432(17.0")	140(5.5")	210(8.3")	460(18.1")	218(8.6")	300(11.8")			154
6	FB	150(5.9")		559(22.0")	562(22.12")	559(22.0")	210(8.3")			272(10.7")	457(18.0")			550
	RB	100(3.9")		559(22.0")	562(22.12")	559(22.0")	172(6.8")			246(9.7")	457(18.0")			348
8	FB	201(7.9")		660(26.0")	664(26.12")	660(26.0")	262(10.3")			348(13.7")	610(24.0")			946
	RB	150(5.9")		660(26.0")	664(26.12")	660(26.0")	210(8.3")			272(10.7")	457(18.0")			682
10	FB	252(9.9")		787(31.0")	791(31.12")	787(31.0")	306(12.0")			396(15.6")	610(24.0")			1,430
	RB	201(7.9")		787(31.0")	791(31.12")	787(31.0")	262(10.3")			348(13.7")	610(24.0")			1,166
12	FB	303(11.9")		838(33.0")	841(33.12")	838(33.0")	348(13.7")			540(21.3")	610(24.0")			2,057
	RB	252(9.9")		838(33.0")	841(33.12")	838(33.0")	306(12.0")			396(15.6")	610(24.0")			1,562
14	FB	334(13.2")		889(35.0")	892(35.12")	889(35.0")	366(14.4")			558(22.0")	762(30.0")			2,816
	RB	252(9.9")		889(35.0")	892(35.12")	889(35.0")	306(12.0")			396(15.6")	762(30.0")			2,200
16	FB	385(15.2")		991(39.0")	994(39.12")	991(39.0")	410(16.1")			610(24.0")	762(30.0")			3,652
	RB	303(11.9")		991(39.0")	994(39.12")	991(39.0")	348(13.7")			540(21.3")	762(30.0")			3,322
18	FB	436(17.2")		1092(43.0")	1095(43.12")	1092(43.0")	445(17.5")			664(26.1")	762(30.0")			5,060
	RB	334(13.2")		1092(43.0")	1095(43.12")	1092(43.0")	366(14.4")			558(22.0")	762(30.0")			4,136
20	FB	487(19.2")		1194(47.0")	1200(47.25")	1194(47.0")	499(19.6")			696(27.4")	762(30.0")			6,600
	RB	385(15.2")		1194(47.0")	1200(47.25")	1194(47.0")	410(16.1")			610(24.0")	762(30.0")			5,764
24	FB	589(23.2")		1397(55.0")	1407(55.38")	1397(55.0")	586(23.1")			812(32.0")	762(30.0")			10,120
	RB	487(19.2")		1397(55.0")	1407(55.38")	1397(55.0")	499(19.6")			696(27.4")	762(30.0")			8,844
26	FB													
	RB	487(19.2")		1448(57.0")	1461(57.5")	1448(57.0")				696(27.4")	762(30.0")			10,824

Class 900		SIZE	*	BORE	ID BORE	RF	RTJ	BW	B	H1	L	H2	OD HW	WEIGHT (LBS)
2	FB	49(1.9")		368(14.5")	371(14.62")	368(14.5")	108(4.3")	160(6.3")	600(23.6")					127.6
	RB	38(1.5")		368(14.5")	371(14.62")	368(14.5")	98(3.9")	146(5.7")	460(18.1")					53
3	FB	74(2.9")		381(15.0")	384(15.12")	381(15.0")	146(5.7")	248(9.8")	600(23.6")					202
	RB	49(1.9")		381(15.0")	384(15.12")	381(15.0")	108(4.3")	160(6.3")	600(23.6")					139
4	FB	100(3.9")		457(18.0")	460(18.12")	457(18.0")	178(7.0")	282(11.1")	600(23.6")	290(11.4")	300(11.8")			308
	RB	74(2.9")		457(18.0")	460(18.12")	457(18.0")	133(5.2")	248(9.8")	600(23.6")	256(10.1")	300(11.8")			251
6	FB	150(5.9")		610(24.0")	613(24.12")	610(24.0")	218(8.6")			309(12.2")	610(24.0")			704
	RB	100(3.9")		610(24.0")	613(24.12")	610(24.0")	178(7.0")			289(11.4")	457(18.0")			462
8	FB	201(7.9")		737(29.0")	740(29.12")	737(29.0")	278(10.9")			398(15.7")	610(24.0")			1,320
	RB	150(5.9")		737(29.0")	740(29.12")	737(29.0")	218(8.6")			309(12.2")	610(24.0")			902
10	FB	252(9.9")		838(33.0")	841(33.12")	838(33.0")	320(12.6")			504(19.8")	762(30.0")			2,002
	RB	201(7.9")		838(33.0")	841(33.12")	838(33.0")	278(10.9")			398(15.7")	610(24.0")			1,562
12	FB	303(11.9")		965(38.0")	968(38.12")	965(38.0")	361(14.2")			546(21.5")	762(30.0")			2,860
	RB	252(9.9")		965(38.0")	968(38.12")	965(38.0")	320(12.6")			504(19.8")	762(30.0")			2,288
14	FB	322(12.7")		1029(40.5")	1038(40.88")	1029(40.5")	399(15.7")			590(23.2")	762(30.0")			3,520
	RB	252(9.9")		1029(40.5")	1038(40.88")	1029(40.5")	320(12.6")			504(19.8")	762(30.0")			3,058
16	FB	373(14.7")		1130(44.5")	1140(44.88")	1130(44.5")	467(18.4")			654(25.7")	762(30.0")			4,972
	RB	303(11.9")		1130(44.5")	1140(44.88")	1130(44.5")	361(14.2")			546(21.5")	762(30.0")			3,850
18	FB													
	RB	322(12.7")		1219(48.0")	1232(48.5")	1219(48.0")				590(23.2")	762(30.0")			5,610

STANDARD VALVE DIMENSIONS - Class 1500 & 2500

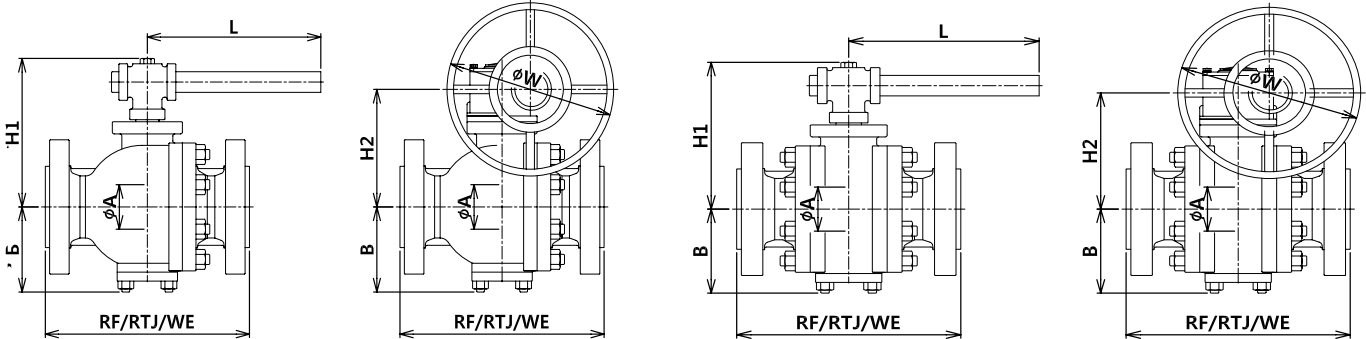

Class 1500

* Available Series:

- CS - 2pc
- CT - 3pc

SIZE	*	BORE	ID BORE	RF	RTJ	BW	B	H1	L	H2	OD HW	WEIGHT (LBS)
2	FB	49(1.9")	368(14.5")	371(14.62")	368(14.5")	108(4.3")	160(6.3")	600(23.6")				128
	RB	38(1.5")	368(14.5")	371(14.62")	368(14.5")	98(3.9")	146(5.7")	460(18.1")				101
3	FB	74(2.9")	470(18.5")	473(18.62")	470(18.5")	152(6.0")	248(9.8")	762(30.0")				242
	RB	49(1.9")	470(18.5")	473(18.62")	470(18.5")	108(4.3")	160(6.3")	600(23.6")				172
4	FB	100(3.9")	546(21.5")	549(21.62")	546(21.5")	197(7.8")	294(11.6")	762(30.0")		302(11.9")	300(11.8")	418
	RB	74(2.9")	546(21.5")	549(21.62")	546(21.5")	152(6.0")	248(9.8")	762(30.0")		256(10.1")	300(11.8")	297
6	FB	144(5.7")	705(27.75")	711(28.0")	705(27.75")	222(8.7")				325(12.8")	610(24.0")	1,100
	RB	100(3.9")	705(27.75")	711(28.0")	705(27.75")	197(7.8")				302(11.9")	457(18.0")	638
8	FB	192(7.6")	832(32.75")	841(33.13")	832(32.75")	290(11.4")				423(16.7")	762(30.0")	1,782
	RB	144(5.7")	832(32.75")	841(33.13")	832(32.75")	222(8.7")				325(12.8")	610(24.0")	1,364
10	FB	239(9.4")	991(39.0")	1000(39.38")	991(39.0")	352(13.9")				560(22.0")	762(30.0")	3,080
	RB	192(7.6")	991(39.0")	1000(39.38")	991(39.0")	290(11.4")				423(16.7")	762(30.0")	2,266
12	FB	287(11.3")	1130(44.5")	1146(45.12")	1130(44.5")	422(16.6")				620(24.4")	762(30.0")	4,730
	RB	239(9.4")	1130(44.5")	1146(45.12")	1130(44.5")	352(13.9")				560(22.0")	762(30.0")	3,696
14	FB	315(12.4")	1257(49.5")	1276(50.25")	1257(49.5")	425(16.7")				653(25.7")	762(30.0")	6,864
	RB	239(9.4")	1257(49.5")	1276(50.25")	1257(49.5")	352(13.9")				560(22.0")	762(30.0")	5,390
16	FB	360(14.2")	1384(54.5")	1407(55.38")	1384(54.5")	493(19.4")				796(31.3")	762(30.0")	9,812
	RB	287(11.3")	1384(54.5")	1407(55.38")	1384(54.5")	422(16.6")				620(24.4")	762(30.0")	8,096
18	FB											
	RB	315(12.4")	1537(60.5")	1559(61.38")	1537(60.5")	425(16.7")				653(25.7")	762(30.0")	10,604

Class 2500

* Available Series:

- CS - 2pc
- CT - 3pc

SIZE	*	BORE	ID BORE	RF	RTJ	BW	B	H1	L	H2	OD HW	WEIGHT (LBS)
2	FB	42(1.7")	451(17.75")	454(17.87")	451(17.75")	120(4.7")	168(6.6")	762(30.0")				242
	RB	38(1.5")	451(17.75")		451(17.75")	104(4.1")	154(6.1")	600(23.6")				220
3	FB	62(2.4")	578(22.75")	584(23.0")	578(22.75")	160(6.3")	252(9.9")	762(30.0")		260(10.2")	300(11.8")	484
	RB	42(1.7")	578(22.75")		578(22.75")	120(4.7")	168(6.6")	762(30.0")		176(6.9")	300(11.8")	341
4	FB	87(3.4")	673(26.5")	683(26.88")	673(26.5")	210(8.3")				320(12.6")	457(18.0")	814
	RB	62(2.4")	673(26.5")		673(26.5")	160(6.3")				260(10.2")	457(18.0")	572
6	FB	131(5.2")	914(36.0")	927(36.5")	914(36.0")	274(10.8")				394(15.5")	610(24.0")	2,090
	RB	87(3.4")	914(36.0")		914(36.0")	210(8.3")				320(12.6")	457(18.0")	1,265
8	FB	179(7.0")	1022(40.25")	1038(40.88")	1022(40.25")	336(13.2")				477(18.8")	762(30.0")	3,344
	RB	131(5.2")	1022(40.25")		1022(40.25")	274(10.8")				260(10.2")	762(30.0")	2,464
10	FB	223(8.8")	1270(50.0")	1292(50.88")	1270(50.0")	425(16.7")				630(24.8")	762(30.0")	6,380
	RB	179(7.0")	1270(50.0")		1270(50.0")	336(13.2")				477(18.8")	762(30.0")	4,378
12	FB	265(10.4")	1422(56.0")	1445(56.88")	1422(56.0")	525(20.7")				706(27.8")	762(30.0")	10,252
	RB	223(8.8")	1422(56.0")		1422(56.0")	425(16.7")				630(24.8")	762(30.0")	7,370
14	FB											
	RB	223(8.8")	1540(60.6")	1569(61.8")	1540(60.6")	425(16.7")				630(24.8")	762(30.0")	10,384

TECHNICAL DATA

PRESSURE / TEMPERATURE LIMITS FOR SOFT SEATS & SEALS

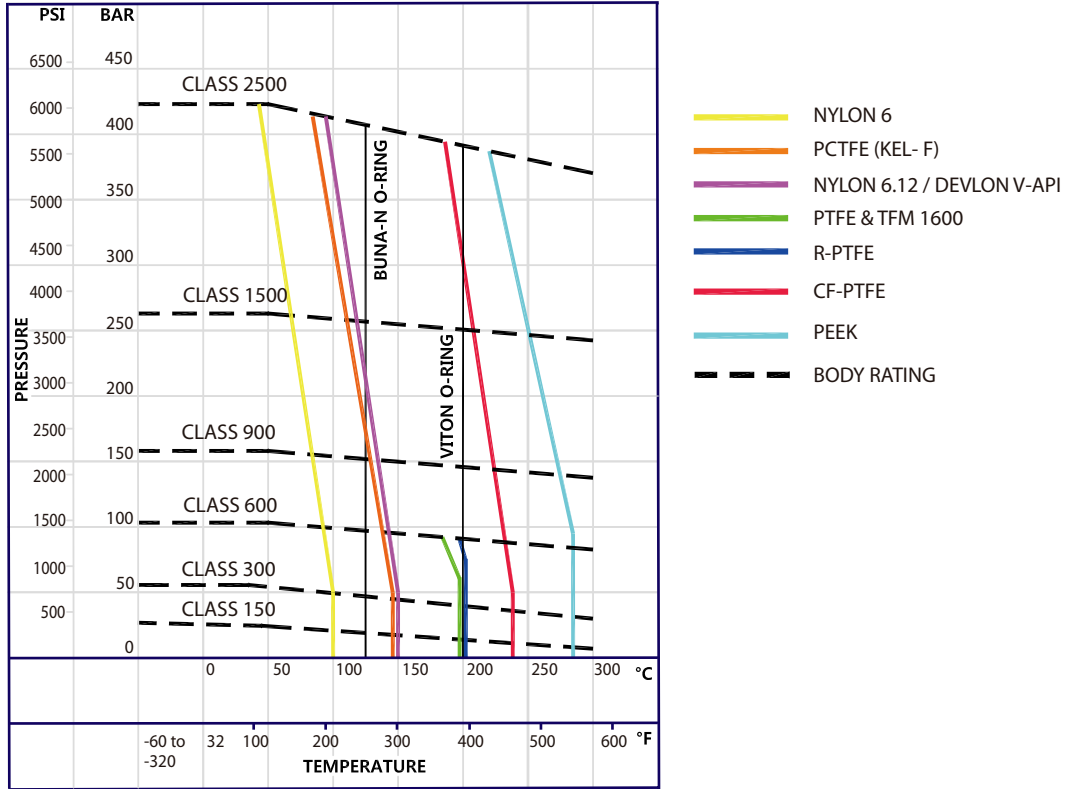

PRESSURE/TEMPERATURE RATINGS
(SOFT SEAT AND SEALS)

SOFT SEAT / SEAL MATERIAL SELECTION & LIMITS

MATERIAL	STATIC / SHORT PERIODS				OPERATING CONDITIONS				MAX. CLASS / RATING	
	TEMP. ° C		TEMP. ° F		TEMP. ° C		TEMP. ° F			
	MIN.	MAX.	MIN.	MAX.	MIN.	MAX.	MIN.	MAX.	SEAT	SEAL
NYLON 6	-40	120	-40	248	-40	100	-40	212	2500	N/A
NYLON 6.12 / DEVLON V-API	-100	190	-148	374	-100	150	-148	302	2500	N/A
PEEK	-100	300	-148	572	-100	270	-148	518	2500	N/A
R-PTFE (25% Filled)	-200	232	-328	450	-200	204	-328	399	600	N/A
PTFE & TFM1600	-200	232	-328	450	-200	204	-328	399	600	N/A
CF-PTFE (Carbon Graphite Filled)	-100	288	-148	550	-100	240	-148	464	900	N/A
PCTFE (KEL-F)	-250	160	-418	320	-250	150	-418	302	2500	N/A
FKM A & B (Viton)	-15	230	-5	446	-10	200	14	392	N/A	2500
FKM GLT (Viton)	-46	210	-50	410	-40	180	-40	356	N/A	2500
NITRILE	-30	150	-22	302	-30	120	-22	248	N/A	2500
HNBR	-46	200	-50	392	-25	180	-13	356	N/A	2500
SILICONE	-60	250	-76	482	-60	200	-76	392	N/A	2500
FLUOROSILICONE	-60	200	-76	392	-60	180	-76	356	N/A	2500
PTFE - INCONEL (Lip Seal)	-200	230	-328	446	-200	200	-328	392	N/A	2500

NOTES

- 1) Temperature limitations may vary between manufacturer grades; always consult with SWI Technical if in doubt.
- 2) Valves Pressure~ temperature (P~T) ratings are limited by the body ratings according to ASME B16.34, seat and seal material limitations.
- 3) Metal seated valves seat P~T ratings are equal to the body ratings or seals where fitted with elastomeric seal material.
- 4) The P~T ratings advised for seats & seals are a general guide; always consult with SWI Technical for specific recommendations.
- 5) Body ratings indicated are for Carbon Steel Material Group 1.1 according to ASME B16.34

VALVE TORQUES

To calculate the valve required torque at any pressure use the formula in the below table.

Example: 6" Full Bore Class 600# Valve fitted with R-PTFE Seats at 1480 psi = $670 + (0.51 \times 1,480) = 1,425\text{Nm}$

NOMINAL INTERNAL PORT SIZE	BALL VALVE OPERATING STEM TORQUES (Nm)														
	RTFE SEAT				RTFE SEAT		NYLON SEAT		NYLON SEAT		NYLON SEAT				
	CL 150# & CL 300				CL 600#		CL 900#		CL 1500#		CL 2500#				
	ΔP (Psi)		285	740	ΔP (Psi)		1480	ΔP (Psi)		2220	ΔP (Psi)		3705	ΔP (Psi)	
1½"	46 + 0.02 *ΔP	52	61	51 + 0.02 *ΔP		81	56 + 0.03 *ΔP		123	61 + 0.03 *ΔP		172	66 + 0.04 *ΔP		313
2"	65 + 0.04 *ΔP	76	95	78 + 0.04 *ΔP		137	85 + 0.05 *ΔP		196	92 + 0.05 *ΔP		277	98 + 0.06 *ΔP		468
3"	148 + 0.10 *ΔP	177	222	178 + 0.12 *ΔP		356	193 + 0.15 *ΔP		526	209 + 0.18 *ΔP		876	222 + 0.19 *ΔP		1,394
4"	250 + 0.19 *ΔP	304	391	301 + 0.23 *ΔP		641	326 + 0.29 *ΔP		970	353 + 0.35 *ΔP		1,650	375 + 0.36 *ΔP		2,596
6"	558 + 0.43 *ΔP	681	876	670 + 0.51 *ΔP		1,425	724 + 0.64 *ΔP		2,145	782 + 0.76 *ΔP		3,598	829 + 0.79 *ΔP		5,703
8"	639 + 0.80 *ΔP	867	1,231	768 + 0.95 *ΔP		2,174	830 + 1.19 *ΔP		3,472	897 + 1.41 *ΔP		6,121	951 + 1.46 *ΔP		9,959
10"	956 + 1.26 *ΔP	1,315	1,888	1,147 + 1.49 *ΔP		3,352	1,239 + 1.87 *ΔP		5,390	1,339 + 2.21 *ΔP		9,527	1,420 + 2.30 *ΔP		15,611
12"	1,375 + 1.84 *ΔP	1,899	2,736	1,650 + 2.18 *ΔP		4,876	1,782 + 2.73 *ΔP		7,843	1,925 + 3.23 *ΔP		13,892	2,041 + 3.35 *ΔP		22,710
14"	1,458 + 2.26 *ΔP	2,309	3,131	1,750 + 2.67 *ΔP		5,702	1,890 + 3.34 *ΔP		9,305	2,042 + 3.95 *ΔP		16,677			
16"	1,936 + 3.10 *ΔP	2,861	4,230	2,324 + 3.66 *ΔP		7,741	2,510 + 4.58 *ΔP		12,678	2,711 + 5.41 *ΔP		22,755			
18"	2,430 + 4.60 *ΔP	4,269	5,834	2,917 + 5.43 *ΔP		10,953									
20"	3,335 + 6.30 *ΔP	5,973	7,997	4,002 + 7.44 *ΔP		15,013									
22"	4,068 + 7.80 *ΔP	7,583	9,840	4,881 + 9.20 *ΔP		18,497									
24"	5,226 + 9.20 *ΔP	7,848	12,034	6,272 + 10.86 *ΔP		22,345									

SIZE	FLOW COEFFICIENT (Cv) RATING					
	CL 150#	CL 300#	CL 600#	CL 900#	CL 1500#	CL 2500#
FB 2"	450	450	400	340	340	290
RB 2"x1½"	110	110	108	106	106	103
FB 3"	1,200	1,200	1,100	950	850	750
RB 3"x2"	198	198	176	150	150	128
FB 4"	2,100	2,100	1,850	1,800	1,650	1,300
RB 4"x3"	528	528	484	418	374	330
FB 6"	5,200	5,200	4,500	4,400	4,000	2,500
RB 6"x4"	924	924	814	792	726	572
FB 8"	9,600	9,600	9,000	8,400	7,900	5,300
RB 8"x6"	2,288	2,288	1,980	1,936	1,760	1,100
FB 10"	16,000	16,000	14,500	14,200	12,000	8,500
RB 10"x8"	4,224	4,224	3,960	3,696	3,476	2,332
FB 12"	25,000	25,000	22,000	21,000	18,190	12,750
RB 12"x10"	7,040	7,040	6,380	6,248	5,280	3,740
FB 14"	29,000	29,000	28,000	26,000	23,000	
RB 14"x10"	6,240	6,240	5,655	5,538	4,680	3,315
FB 16"	40,000	40,000	38,000	35,000	30,000	
RB 16"x12"	11,000	11,000	9,680	9,240	8,004	
FB 18"	52,000	52,000	50,000			
RB 18"x14"	11,310	11,310	10,920	10,140	8,970	
FB 20"	65,000	65,000	60,000			
RB 20"x16"	15,600	15,600	14,820			
FB 24"	100,000	100,000	94,000			
RB 24"x20"	27,300	27,300	25,200			
FB 26"	110,000	110,000				
RB 26"x20"	25,350	25,350				
FB 28"	126,000	126,000				
RB 28"x24"	44,000	44,000				
FB 30"	150,000	150,000				
RB 30"x24"	37,000	37,000				
FB 36"	211,000	211,000				
RB 36"x30"	66,000	66,000				
FB 40"	268,000	268,000				
RB 48" X 40"	108,000	108,000				

BALL VALVE TORQUE NOTES

- Torque values advised are for new valves, based on clean water / lubricated service.
- No additional safety factors have been included.
- For actuated valves, it is recommended a minimum of 30% safety is applied, unless advised or required otherwise by client.
- For infrequent use i.e. less than once per month, add 50%
- For lubricated service with oil, torques may be reduced between 10%~20% dependant upon the application.
- For Dry Gas add 25%, minimum.
- For Paste, Resin, Slurry, & Pulp, add 50%, minimum.
- For fluids carrying dust, powder and entrained particles, dirty service, add 50~100% dependent upon the nature of the service.
- Temperatures below -29°C and above 120°C, consult SWI Engineering.
- For stem mast maximum allowable torque, consult SWI Engineering.
- For alternative seat materials (i.e. PEEK) and Metal Seats, consult SWI Engineering.
- If in doubt, always consult SWI Engineering.

FLOW COEFFICIENT NOTE

Cv is defined as the volume of water flowing through the valve, in U.S. Gallons per minute at 60°F (15°C), which will result in a pressure drop of 1 psi.

VALVE MODEL NUMBER

CODE TABLE **A B C D E F G H J K (Optional)**
Sample Valve Code **CS B 11S2 R1 - R 2 1 1 2**
 2-PCE, CLASS 150#, WCB BODY, 316SS TRIM, R-PTFE SEAT, HNBR (AED GRADE) PRIMARY SEAL
 B7/2H BOLTING, FLANGED & DRILLED ANSI 150 RF, FULL BORE, STD. BONNET, WRENCH OPERATED
 SEALANT INJECTION FACILITY TO SEAT AREA

A		B		C		D			
VALVE TYPE / SERIES		CLASS		SHELL MATERIAL BODY / BONNET / COVER		TRIM MATERIAL			
							BALL	SEAT RINGS	STEM / TRUNNION
CS	2 PIECE BOLTED BODY	B	150#	11	A216-WCB/A105	C1	WCB/ENP	A105/ENP	316 SS
CT	3 PIECE BOLTED BODY	D	300#	13	A352-LCC / A350-LF2	S1	410SS	410SS	410SS
		E	600#	23	A351-CF8M / A182-F316	S2	304SS	304SS	304SS
		G	900#	24	A351-CF3M / A182-F316L	S3	316 SS	316 SS	316 SS
		H	1500#	29	ASTM A890-4A / A182-F51	S4	316LSS	316L SS	316L SS
		J	2500#	30	ASTM A890-5A / A182-F53	S5	316 SS	316 SS	17/4PH SS
		9	OTHER	31	ASTM A890-6A / A182-F55	D1	F51 / S31803	F51 / S31803	F51 / S31803
				33	ASTM A494-M35-1 / MONEL 400	D2	F53 / S32750	F53 / S32750	F53 / S32750
				35	ASTM A494-CW6MC / INCONEL 625	D3	F55 / S32760	F55 / S32760	F55 / S32760
				44	ASTM A351-CK3MCUN / A182-F44	D4	F44/ S31254	F44/ S31254	F44/ S31254
				61	ASTM B148 - C95800	A6	INCONEL 625	INCONEL 625	INCONEL 625
				99	SPECIAL	B2	B148-C95800 / NiAlBz	NiAlBz	NiAlBz
						99		SPECIAL	

E SEAL MATERIAL ^(1&2)		
	SEAT	PRIMARY SEAL
K1	KEL-F / PCTFE	HNBR AED
K4	KEL-F / PCTFE	PTFE + ELGILOY SPRING
N1	NYLON 6.12 / DEVLON	HNBR AED
N2	NYLON 6.12 / DEVLON	FKMB (Viton)
N3	NYLON 6.12 / DEVLON	FKM GLT (Viton)
P1	PEEK	HNBR AED
P2	PEEK	FKMB (Viton)
P3	PEEK	FKM GLT (Viton)
P4	PEEK	PTFE + ELGILOY SPRING
P5	PEEK	GARLOCK 9000 EVSP
R1	R-PTFE	HNBR AED
R2	R-PTFE	FKM B (Viton)
R3	R-PTFE	FKM GLT (Viton)
R4	R-PTFE	PTFE + ELGILOY SPRING
R5	R-PTFE	GARLOCK 9000 EVSP
M ⁽³⁾	METAL SEATED	

- (1) Secondary seals are Graphite
- (2) Body gaskets are Graphite or Spiral Wound Gaskets.
- (3) Metal seating and primary seal selection to suit application.

F END CONNECTION	
W ⁽⁴⁾	BUTT WELDASME B16.25
R	FLANGED - ASME B16.5 RF
F	FLANGED - ASME B16.5 FF
J	FLANGED - ASME B16.5 RTJ
G ⁽⁵⁾	FLANGED - ASME B16.47 RF
H ⁽⁶⁾	HUB ENDS

- (4) Pipe schedule to be specified
- (5) Series A or B to be specified
- (6) Customer to specify

G BORE	
1	REDUCED BORE
2	FULL BORE
g ⁽⁶⁾	SPECIAL BORE

H BONNET	
1	STANDARD BONNET
2	LOW TEMP. -46°C
3	CRYOGENIC -46°C ~ -196°C
5	LAGGING EXTENSION
6	HEAT DISSIPATION BONNET
7	UNDERGROUND
9	LOW EMISSION SEAL SYSTEM

J OPERATION	
0	BARE STEM
1	WRENCH OPERATED
2	WRENCH OPERATED - LD
3	GEAR OPERATED
4	GEAR OPERATED - LD
P	PNEUMATIC
E	ELECTRIC (MOV)
H	HYDRAULIC
G	GAS OVER OIL
EH	ELECTRO HYDRAULIC

LD = Open & Closed Locking Facility

K (Optional) ANCILLARIES	
1	INJECTION FACILITY, STEM AREA
2	INJECTION FACILITY, SEAT AREA
3	INJECTION FACILITY, STEM & SEAT AREA

BOLTING MATERIAL ^(5 & 6)		
BODY CODE	BOLT	NUT
11	A193-B7	A194-2H
13	A320-L7	A194-4
23	A193-B8	A194-8
24	A193-B8	A194-8
29	A193-B8M CL2	A194-8M
31	A193-B8M CL2	A194-8M
33	A193-B8M CL2	A194-8M
35	A193-B8M CL2	A194-8M
44	A193-B8M CL2	A194-8M
61	A193-B8M	A194-8M

- (5) SWI standard bolting unless specified otherwise.
- (6) For NACE, Grade 'M' applied

How to Read SWI Valve Name Plate	
1	CE Mark and Notified Body, when applied
2	ATEX mark, when applied
3	ANSI pressure class
4	NPS size (Inches)
5	Materials of construction for main parts
6	Test / Sealing configuration per API 6D
7	Firesafe Standard
8	Valve max. pressure at min. design temperature
9	Valve max. pressure at max. design temperature
10	Valve model / figure number
11	Valve serial number
12	Date of manufacture (Month / Year)
13	Applied design code
14	API 6D Monogram, when applicable.
15	Country of manufacture.

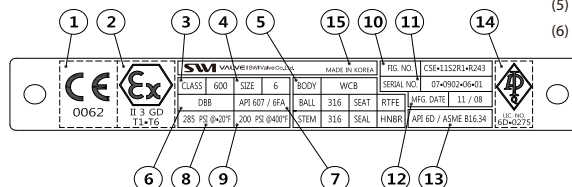

ACTUATION & OPERATION

SWI's range of valves may be manually operated by lever or gearbox depending on torque requirements, and are built to easily accept pneumatic, hydraulic or electric actuators.

Valve design minimizes operational torque, which normally affects actuator sizing, allowing for economical automation packages. Complete valve / actuator assemblies can be provided fully tested and certified according to customer requirements as a single package, supplied directly from SWI.

Over many years, SWI has built up a reputation for providing high quality valves supported by factory field experts. To maintain and extend our reputation, we have aligned ourselves with highly accredited and respected Automation Manufacturers in the industry. This combined with fully equipped valve automation assembly & test and our extensive knowledge of the valves and actuator requirements, SWI can offer competitive prices, best service and proven products.

Production is centered at our new 14,500 m² World Class facility near Seoul with all manufacturing processes covered by the same documentation that ensures compliance to our standardized quality assurance programs. Product quality has been subject to continued enhancements and all products are constantly reviewed so as to improve quality and maintainability.

From general on / off duty with position indication and solenoid control to complete modulating packages with smart positioners, regulators, partial stroke and sophisticated control systems are all available from SWI.

SWI's trunnion mounted ball valves are ideal for ESD applications due to the inherently robust design with greater stem to ball drive train strength. Valves specified as ESD are equipped with actuators which ensure their positive operation in an emergency. In the case of such critical equipment, full details of the application conditions and relevant specifications should always be provided to our technical department.

To provide further customer support, SWI has partnered with key companies worldwide to distribute products and respond quickly to our client needs.



METAL TO METAL SEATED VALVES

For applications where solid particles may be present in the fluid or involve very high pressure and / or elevated temperature beyond the capability of soft seats, SWI can provide valves with metal to metal seating. SWI achieves the metal to metal seating through the use of various advanced hard facing technologies incorporating Tungsten Carbide coatings, Stellite, Hard Nickel Alloy or alternative processes considering the intended application.

Please consult with our technical department for specific requirements.

OPTIONS & VARIATIONS

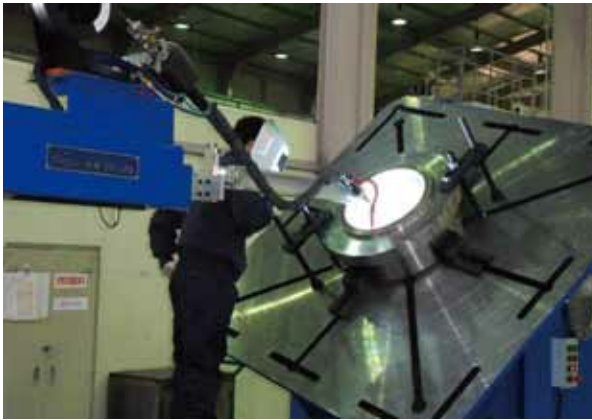

WELD OVERLAY TECHNOLOGY

SWI fully automated robotic welding offers a cost effective solution compared to solid corrosion resistant alloys.

Where highly corrosive or erosive services are involved, the life expectancy of a valve can be considerably extended by the application local weld overlay or full internal cladding to valve internal surfaces.

LOW TEMPERATURE SERVICE

SWI ball valves can be supplied for use in low temperature or cryogenic service. Extended bonnets of the vapour space type are available for service temperatures down to minus 196 • .

UNDERGROUND / EXTENDED OPERATOR

Operator extensions may be required where valves are to be installed in underground (buried service) locations or whereby extended operators are required due to inaccessibility. SWI can offer a full range of extensions in a wide range of materials, from simple spindle type extensions to fully enclosed and oil filled type extensions.

Extensions and lengths are manufactured according to client requirements and may also be fitted with the necessary piping to facilitate drain, vent and sealant injection or lubrication as required.

SOUR SERVICE

Valves are available conforming to the requirements of the NACE specification MR 01-75 / ISO 15156 / MR 01-03 for use on applications where the presence of wet H₂S generates a risk of stress corrosion cracking. NACE compliance certificates are available on request.



QUALITY ASSURANCE

SWI Valves operate under a Quality Assurance system which is approved by Bureau Veritas to ISO 9001:2008 / KS Q ISO 9001: 2009 / KEPIC-MN and API Q1. The company is licensed to use the API Monogram in respect of API 6D ball valves and our facilities are always open to customer audits.

SWI ball valves have been independently accredited for Design and Fire Safety. In addition, manufacture and materials comply with the essential safety requirements of the Pressure Equipment Directive 97/23/EC (PED).



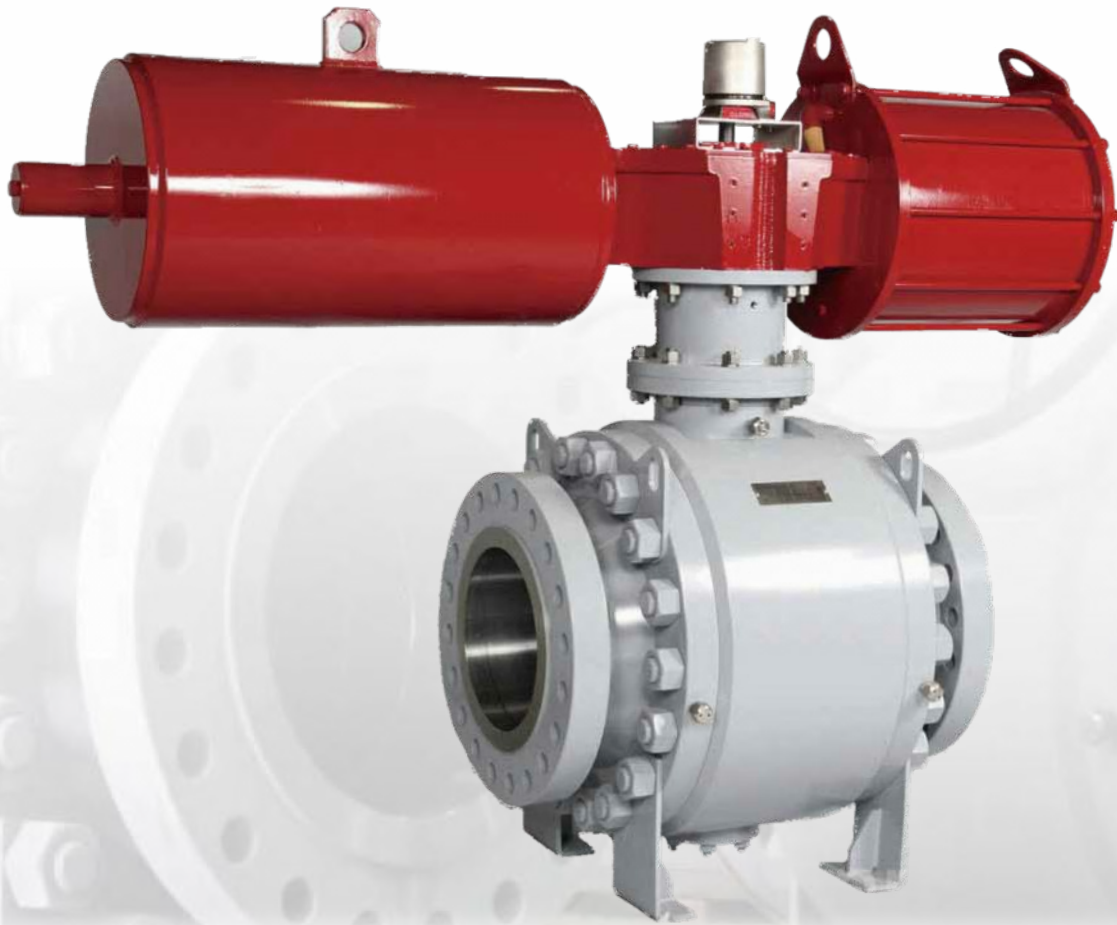

Products Manufactured by SWI Include :

- Ball Valves, Soft & Metal Seated
- Forged Steel Gate, Globe & Check Valves
- Cast & Forged Bellows Seal Gate and Globe Valves
- Cryogenic Valves down to minus 196 °C
- High Alloy Valves
- Top Entry Valves
- Fully Automated Valves, Pneumatic, Electric, Hydraulic & Gas Over Oil Systems

HEAD OFFICE & PLANT 1

SWI Valve Co., Ltd.
1023-2 Gwanyang-dong, Dongan-gu
Anyang-si, Gyeonggi-do
KOREA

Tel:+82 31 421 1831~3
Fax:+82 31 421 1834
WebSite:www.swivalve.com

PLANT 2

SWI Valve Co., Ltd.
801-2 Goryeom-ri, Cheongbuk-myeon
Pyeongtaek-si, Gyeonggi-do
KOREA

Tel:+82 31 684 2981~3
Fax:+82 31 684 2984

USA OFFICE

SWI Valve Corporation
10101 Harwin Drive, Suite
173 Houston, Texas 77036
USA

Tel:+1 713 266 7033
Fax:+1 713 266 7034